

CX18C
Mini Excavator

SERVICE MANUAL

Part number 48139721

English
June 2017





SERVICE MANUAL

**CX18C Cab - Tier IV Engine
CX18C Canopy - Tier IV Engine**

Contents

INTRODUCTION

Engine.....	10
[10.001] Engine and crankcase	10.1
[10.106] Valve drive and gears	10.2
[10.101] Cylinder heads	10.3
[10.105] Connecting rods and pistons.....	10.4
[10.103] Crankshaft and flywheel.....	10.5
[10.216] Fuel tanks	10.6
[10.206] Fuel filters	10.7
[10.220] Throttle linkage	10.8
[10.218] Fuel injection system.....	10.9
[10.202] Air cleaners and lines	10.10
[10.254] Intake and exhaust manifolds and muffler	10.11
[10.400] Engine cooling system	10.12
[10.414] Fan and drive	10.13
[10.304] Engine lubrication system.....	10.14
Hydraulic systems.....	35
[35.000] Hydraulic systems.....	35.1
[35.300] Reservoir, cooler, and filters.....	35.2
[35.106] Variable displacement pump	35.3
[35.359] Main control valve.....	35.4
[35.357] Pilot system	35.5
[35.355] Hydraulic hand control	35.6
[35.356] Hydraulic foot control.....	35.7
[35.352] Hydraulic swing system	35.8
[35.353] Hydraulic travel system	35.9
[35.354] Hydraulic central joint	35.10

[35.735] Track frame widening system	35.11
[35.736] Boom hydraulic system	35.12
[35.737] Dipper hydraulic system.....	35.13
[35.738] Excavator and backhoe bucket hydraulic system.....	35.14
[35.734] Tool quick coupler hydraulic system	35.15
[35.739] Swing arm hydraulic system	35.16
[35.741] Dozer blade cylinders	35.17
Frames and ballasting	39
[39.140] Ballasts and supports	39.1
Tracks and track suspension.....	48
[48.130] Track frame and driving wheels.....	48.1
[48.100] Tracks	48.2
[48.134] Track tension units	48.3
[48.138] Track rollers	48.4
Electrical systems.....	55
[55.000] Electrical system	55.1
[55.100] Harnesses and connectors.....	55.2
[55.525] Cab engine controls.....	55.3
[55.015] Engine control system.....	55.4
[55.201] Engine starting system	55.5
[55.301] Alternator.....	55.6
[55.302] Battery.....	55.7
[55.202] Cold start aid	55.8
[55.011] Fuel tank system	55.9
[55.014] Engine intake and exhaust system.....	55.10
[55.012] Engine cooling system	55.11
[55.013] Engine oil system	55.12
[55.512] Cab controls.....	55.13

[55.524] Cab controls (Lift arm, Boom, Dipper, Bucket)	55.14
[55.518] Wiper and washer system.....	55.15
[55.404] External lighting	55.16
[55.405] External lighting switches and relays	55.17
[55.514] Cab lighting	55.18
[55.408] Warning indicators, alarms, and instruments	55.19
Booms, dippers, and buckets	84
[84.910] Boom.....	84.1
[84.912] Dipper arm	84.2
[84.100] Bucket.....	84.3
Dozer blade and arm.....	86
[86.110] Dozer blade	86.1
Platform, cab, bodywork, and decals	90
[90.160] Cab interior trim and panels.....	90.1
[90.114] Operator protections	90.2
[90.120] Mechanically-adjusted operator seat.....	90.3
[90.100] Engine hood and panels	90.4
[90.105] Machine shields and guards	90.5



INTRODUCTION

Contents

INTRODUCTION

Foreword - Important notice regarding equipment servicing	3
Safety rules	4
Safety rules - General information	5
Safety rules - Personal safety	6
Safety rules - Ecology and the environment	9
Torque - Standard torque settings	10
Torque - Special torque settings	12
Basic instructions - Shop and assembly	13
Machine specifications	15
Weights	17
Dimensions	18
Conversion factors	21
Hydraulic contamination	33
General specification	34
Fluids and lubricants	36
Product identification	40
Product identification	43

Foreword - Important notice regarding equipment servicing

All repair and maintenance work listed in this manual must be carried out only by qualified dealership personnel, strictly complying with the instructions given, and using, whenever possible, the special tools.

Anyone who performs repair and maintenance operations without complying with the procedures provided herein shall be responsible for any subsequent damages.

The manufacturer and all the organizations of its distribution chain, including - without limitation - national, regional, or local dealers, reject any responsibility for damages caused by parts and/or components not approved by the manufacturer, including those used for the servicing or repair of the product manufactured or marketed by the manufacturer. In any case, no warranty is given or attributed on the product manufactured or marketed by the manufacturer in case of damages caused by parts and/or components not approved by the manufacturer.

The manufacturer reserves the right to make improvements in design and changes in specifications at any time without notice and without incurring any obligation to install them on units previously sold. Specifications, descriptions, and illustrative material herein are as accurate as known at time of publication but are subject to change without notice.

In case of questions, refer to your CASE CONSTRUCTION Sales and Service Networks.

Safety rules

Personal safety





This is the safety alert symbol. It is used to alert you to potential personal injury hazards. Obey all safety messages that follow this symbol to avoid possible death or injury.

Throughout this manual you will find the signal words DANGER, WARNING, and CAUTION followed by special instructions. These precautions are intended for the personal safety of you and those working with you.

Read and understand all the safety messages in this manual before you operate or service the machine.

 DANGER indicates a hazardous situation that, if not avoided, will result in death or serious injury.

 WARNING indicates a hazardous situation that, if not avoided, could result in death or serious injury.

 CAUTION indicates a hazardous situation that, if not avoided, could result in minor or moderate injury.

FAILURE TO FOLLOW DANGER, WARNING, AND CAUTION MESSAGES COULD RESULT IN DEATH OR SERIOUS INJURY.

Machine safety

NOTICE: Notice indicates a situation that, if not avoided, could result in machine or property damage.

Throughout this manual you will find the signal word Notice followed by special instructions to prevent machine or property damage. The word Notice is used to address practices not related to personal safety.

Information

NOTE: Note indicates additional information that clarifies steps, procedures, or other information in this manual.

Throughout this manual you will find the word Note followed by additional information about a step, procedure, or other information in the manual. The word Note is not intended to address personal safety or property damage.

Safety rules - General information

Cleaning

Clean the metal parts with cleaning solution that meets the standard and steam cleaning. (except for bearings)

After cleaning, dry well, and inject oil in all parts.

Also inject oil into the bearings after drying.

Inspection

When disassembling parts, check all the parts.

If there are any worn or damaged parts, replace them.

Inspect carefully to prevent initial breakdowns.

Bearing

Replace any loose bearings.

Air dry bearings before installing them.

Needle bearing

When inserting needle bearings, be very careful not to damage them.

Apply grease to the section where the needle bearing will be inserted.

Gear

Check that there is no wear and no damage.

Oil seal, O-ring, gasket

Always install new oil seals, O-rings, and gaskets.

Apply grease to sections where oil seals and O-rings will be inserted.

Shaft

Check that there is no wear and no damage.

Check the bearings and check for damaged oil seals on the shaft.

Service parts

Install CASE CONSTRUCTION genuine service parts.

When placing an order, check the parts catalog. It contains the CASE CONSTRUCTION genuine part numbers.

Any breakdowns arising from the installation of non-genuine parts are not covered by the warranty.

Lubricants (fuel, hydraulic oil)

Use the oil from the specified company or specified in the operator's manual or service Manual.

Any breakdowns arising from any fuel or hydraulic oil other than those specified are not covered by the warranty.

Safety rules - Personal safety

Preliminary warnings to maintenance operation

⚠ WARNING

Avoid injury!

Shut off the engine, remove the key, and make sure all machine motion stops before you service the machine.

Failure to comply could result in death or serious injury.

W1128B

⚠ WARNING

Improper operation or service of this machine can result in an accident.

Assign a supervisor to direct worksite operations. Agree on all safety measures, procedures, and suitable hand signals.

Failure to comply could result in death or serious injury.

W0287A

⚠ CAUTION

Pinch hazard!

Always use suitable tools to align mating parts. **DO NOT** use your hand or fingers.

Failure to comply could result in minor or moderate injury.

C0044A

Personal Protective Equipment (PPE)

⚠ WARNING

Avoid injury!

Use Personal Protective Equipment (PPE), including protective goggles, gloves, and safety footwear.

Failure to comply could result in death or serious injury.

W1036A

Lifting operation

⚠ WARNING

Crushing hazard!

The lifting systems must be operated by qualified personnel who are aware of the correct procedures to follow. Make sure all lifting equipment is in good condition, and all hooks are equipped with safety latches.

Failure to comply could result in death or serious injury.

W0256A

⚠ WARNING

Heavy objects!

Lift and handle all heavy components using lifting equipment with adequate capacity. Always support units or parts with suitable slings or hooks. Make sure the work area is clear of all bystanders.

Failure to comply could result in death or serious injury.

W0398A

⚠ WARNING

Improper operation or service of this machine can result in an accident.

Raised equipment or machine movement without an operator can cause serious injury. Always do the following before performing any maintenance:

Park the machine on flat, level ground.

Lower the attachment to the ground.

Shut down the engine and remove the ignition key.

Lock the tracks.

Failure to comply could result in death or serious injury.

W0944D

⚠ WARNING

Tip-over hazard!
Only raise the track as little as necessary.
Failure to comply could result in death or serious injury.

W0276A

Hydraulic system

⚠ WARNING

Burn hazard!
Before performing any service on the hydraulic system, you must allow it to cool. Hydraulic fluid temperature should not exceed 40 °C (104 °F).
Failure to comply could result in death or serious injury.

W0241A

⚠ WARNING

Pressurized fluid can penetrate the skin and cause severe injuries.
The grease in the cylinder is under high pressure. Never loosen the grease fitting adaptor completely in order to speed up the flow of grease.
Failure to comply could result in death or serious injury.

W0261A

⚠ WARNING

Pressurized system!
Before attempting any service procedure, it is your responsibility to know the number of accumulators on the machine, and the correct procedure for releasing the pressure of each accumulator.
Failure to comply could result in death or serious injury.

W0136A

Battery

⚠ WARNING

Battery acid causes burns. Batteries contain sulfuric acid.
Avoid contact with skin, eyes or clothing. Antidote (external): Flush with water. Antidote (eyes): flush with water for 15 minutes and seek medical attention immediately. Antidote (internal): Drink large quantities of water or milk. Do not induce vomiting. Seek medical attention immediately.
Failure to comply could result in death or serious injury.

W0111A

⚠ WARNING

Battery gas can explode!
To prevent an explosion: 1. Always disconnect the negative (-) battery cable first. 2. Always connect the negative (-) battery cable last. 3. Do not short circuit the battery posts with metal objects. 4. Do not weld, grind, or smoke near a battery.
Failure to comply could result in death or serious injury.

W0011A

Fluids

⚠ WARNING

Hazardous chemicals!
Coolant can be toxic. Avoid contact with skin, eyes, and clothing. Antidotes:
EXTERNAL - Rinse thoroughly with water. Remove soiled clothing.
INTERNAL - Rinse the mouth with water. DO NOT induce vomiting. Seek immediate medical attention.
EYES - Flush with water. Seek immediate medical attention.
Failure to comply could result in death or serious injury.

W0282A

⚠ WARNING

Burn hazard!

Hot coolant can spray and scald if you remove the radiator or deaeration tank cap while the system is hot. To remove the cap: allow the system to cool, turn the cap to the first notch, and wait for all pressure to release. Remove the cap only after all pressure has released.

Failure to comply could result in death or serious injury.

W0367A

⚠ WARNING

Escaping fluid!

Hydraulic fluid or diesel fuel leaking under pressure can penetrate the skin and cause infection or other injury. To prevent personal injury: Relieve all pressure before disconnecting fluid lines or performing work on the hydraulic system. Before applying pressure, make sure all connections are tight and all components are in good condition. Never use your hand to check for suspected leaks under pressure. Use a piece of cardboard or wood for this purpose. If injured by leaking fluid, see your doctor immediately.

Failure to comply could result in death or serious injury.

W0178A

⚠ WARNING

Chemical hazard!

When handling fuel, lubricants, and other service chemicals, follow the manufacturer's instructions. Wear Personal Protective Equipment (PPE) as instructed. Do not smoke or use open flame. Collect fluids in proper containers. Obey all local and environmental regulations when disposing of chemicals.

Failure to comply could result in death or serious injury.

W0371A

Safety rules - Ecology and the environment

Soil, air, and water quality is important for all industries and life in general. When legislation does not yet rule the treatment of some of the substances that advanced technology requires, sound judgment should govern the use and disposal of products of a chemical and petrochemical nature.

Familiarize yourself with the relative legislation applicable to your country, and make sure that you understand this legislation. Where no legislation exists, obtain information from suppliers of oils, filters, batteries, fuels, anti-freeze, cleaning agents, etc., with regard to the effect of these substances on man and nature and how to safely store, use, and dispose of these substances.

Helpful hints

- Avoid the use of cans or other inappropriate pressurized fuel delivery systems to fill tanks. Such delivery systems may cause considerable spillage.
- In general, avoid skin contact with all fuels, oils, acids, solvents, etc. Most of these products contain substances that may be harmful to your health.
- Modern oils contain additives. Do not burn contaminated fuels and or waste oils in ordinary heating systems.
- Avoid spillage when you drain fluids such as used engine coolant mixtures, engine oil, hydraulic fluid, brake fluid, etc. Do not mix drained brake fluids or fuels with lubricants. Store all drained fluids safely until you can dispose of the fluids in a proper way that complies with all local legislation and available resources.
- Do not allow coolant mixtures to get into the soil. Collect and dispose of coolant mixtures properly.
- The air-conditioning system contains gases that should not be released into the atmosphere. Consult an air-conditioning specialist or use a special extractor to recharge the system properly.
- Repair any leaks or defects in the engine cooling system or hydraulic system immediately.
- Do not increase the pressure in a pressurized circuit as this may lead to a component failure.
- Protect hoses during welding. Penetrating weld splatter may burn a hole or weaken hoses, allowing the loss of oils, coolant, etc.

Battery recycling

Batteries and electric accumulators contain several substances that can have a harmful effect on the environment if the batteries are not properly recycled after use. Improper disposal of batteries can contaminate the soil, groundwater, and waterways. CASE CONSTRUCTION strongly recommends that you return all used batteries to a CASE CONSTRUCTION dealer, who will dispose of the used batteries or recycle the used batteries properly. In some countries, this is a legal requirement.



Mandatory battery recycling

NOTE: The following requirements are mandatory in Brazil.

Batteries are made of lead plates and a sulfuric acid solution. Because batteries contain heavy metals such as lead, CONAMA Resolution 401/2008 requires you to return all used batteries to the battery dealer when you replace any batteries. Do not dispose of batteries in your household garbage.

Points of sale are obliged to:

- Accept the return of your used batteries
- Store the returned batteries in a suitable location
- Send the returned batteries to the battery manufacturer for recycling

Torque - Standard torque settings

BOLT AND NUT

Use following table for unspecified torque.

Coarse thread

Bolt size	Wrench	8 t	10 t
M6 x 1.0	10 mm	8.34 – 12.26 N·m (6.15 – 9.04 lb ft)	11.12 – 17.08 N·m (8.20 – 12.60 lb ft)
M8 x 1.25	13 mm	19.66 – 29.42 N·m (14.50 – 21.70 lb ft)	26.44 – 40.27 N·m (19.50 – 29.70 lb ft)
M10 x 1.5	17 mm	39.18 – 58.84 N·m (28.90 – 43.40 lb ft)	53.96 – 81.35 N·m (39.80 – 60.00 lb ft)
M12 x 1.75	19 mm	72.54 – 109.82 N·m (53.50 – 81.00 lb ft)	96.13 – 154.56 N·m (70.90 – 114.00 lb ft)
M14 x 2.0	22 mm	119.58 – 162.70 N·m (88.20 – 120.00 lb ft)	164.05 – 221.00 N·m (121.00 – 163.00 lb ft)
M16 x 2.0	24 mm	183.04 – 246.76 N·m (135.00 – 182.00 lb ft)	246.76 – 334.89 N·m (182.00 – 247.00 lb ft)
M18 x 2.5	27 mm	253.54 – 343.02 N·m (187.00 – 253.00 lb ft)	344.38 – 466.40 N·m (254.00 – 344.00 lb ft)
M20 x 2.5	30 mm	355.22 – 479.96 N·m (262.00 – 354.00 lb ft)	482.67 – 653.50 N·m (356.00 – 482.00 lb ft)
M22 x 2.5	32 mm	473.18 – 620.96 N·m (349.00 – 458.00 lb ft)	645.37 – 961.27 N·m (476.00 – 709.00 lb ft)
M24 x 3.0	36 mm	612.83 – 828.40 N·m (452.00 – 611.00 lb ft)	833.83 – 1128.04 N·m (615.00 – 832.00 lb ft)
M30 x 3.0	46 mm	1217.52 – 1645.96 N·m (898.00 – 1214.00 lb ft)	1658.17 – 2245.23 N·m (1223.00 – 1656.00 lb ft)
M36 x 4.0	55 mm	1709.69 – 2310.31 N·m (1261.00 – 1704.00 lb ft)	2451.32 – 3039.74 N·m (1808.00 – 2242.00 lb ft)

Fine thread

Bolt size	Wrench	8 t	10 t
M 8 x 1.0	13 mm	21.56 – 33.35 N·m (15.90 – 24.60 lb ft)	29.42 – 43.12 N·m (21.70 – 31.80 lb ft)
M10 x 1.2	17 mm	44.06 – 65.76 N·m (32.50 – 48.50 lb ft)	57.89 – 87.31 N·m (42.70 – 64.40 lb ft)
M12 x 1.25	19 mm	76.47 – 113.75 N·m (56.40 – 83.90 lb ft)	103.99 – 157.27 N·m (76.70 – 116.00 lb ft)
M14 x 1.5	22 mm	130.43 – 177.61 N·m (96.20 – 131.00 lb ft)	176.26 – 235.91 N·m (130.00 – 174.00 lb ft)
M16 x 1.5	24 mm	195.24 – 264.38 N·m (144.00 – 195.00 lb ft)	260.32 – 352.51 N·m (192.00 – 260.00 lb ft)
M18 x 1.5	27 mm	280.65 – 427.08 N·m (207.00 – 315.00 lb ft)	376.92 – 509.79 N·m (278.00 – 376.00 lb ft)
M20 x 1.5	30 mm	391.83 – 530.12 N·m (289.00 – 391.00 lb ft)	523.35 – 707.74 N·m (386.00 – 522.00 lb ft)
M22 x 1.5	32 mm	516.57 – 699.60 N·m (381.00 – 516.00 lb ft)	692.82 – 938.23 N·m (511.00 – 692.00 lb ft)
M24 x 2.0	36 mm	665.71 – 901.62 N·m (491.00 – 665.00 lb ft)	892.13 – 1206.68 N·m (658.00 – 890.00 lb ft)
M30 x 2.0	46 mm	1342.26 – 1815.44 N·m (990.00 – 1339.00 lb ft)	1781.54 – 2435.05 N·m (1314.00 – 1796.00 lb ft)
M36 x 3.0	55 mm	1884.59 – 2548.94 N·m (1390.00 – 1880.00 lb ft)	2567.92 – 3473.61 N·m (1894.00 – 2562.00 lb ft)

Pipe and hose (FLARE type)

Thread size (PF)	Wrench	Torque
1/4"	19 mm	39.18 N·m (28.90 lb ft)
3/8"	22 mm	49.08 N·m (36.20 lb ft)
1/2"	27 mm	93.14 N·m (68.70 lb ft)
3/4"	36 mm	176.26 N·m (130.00 lb ft)
1"	41 mm	206.08 N·m (152.00 lb ft)
1-1/4"	50 mm	343.02 N·m (253.00 lb ft)

Pipe and hose (ORFS type)

Thread size (UNF)	Wrench	Torque
9/16-18	19 mm	39.18 N·m (28.90 lb ft)
11/16-16	22 mm	49.08 N·m (36.20 lb ft)
13/16-16	27 mm	93.14 N·m (68.70 lb ft)

INTRODUCTION

Thread size (UNF)	Wrench	Torque
1-3/16-12	36 mm	176.26 N·m (130.00 lb ft)
1-7/16-12	41 mm	206.08 N·m (152.00 lb ft)
1-11/16-12	50 mm	343.02 N·m (253.00 lb ft)

Fitting

Thread size	Wrench	Torque
1/4"	19 mm	39.18 N·m (28.90 lb ft)
3/8"	22 mm	49.08 N·m (36.20 lb ft)
1/2"	27 mm	93.14 N·m (68.70 lb ft)
3/4"	36 mm	176.26 N·m (130.00 lb ft)
1"	41 mm	206.08 N·m (152.00 lb ft)
1-1/4"	50 mm	343.02 N·m (253.00 lb ft)

Working range

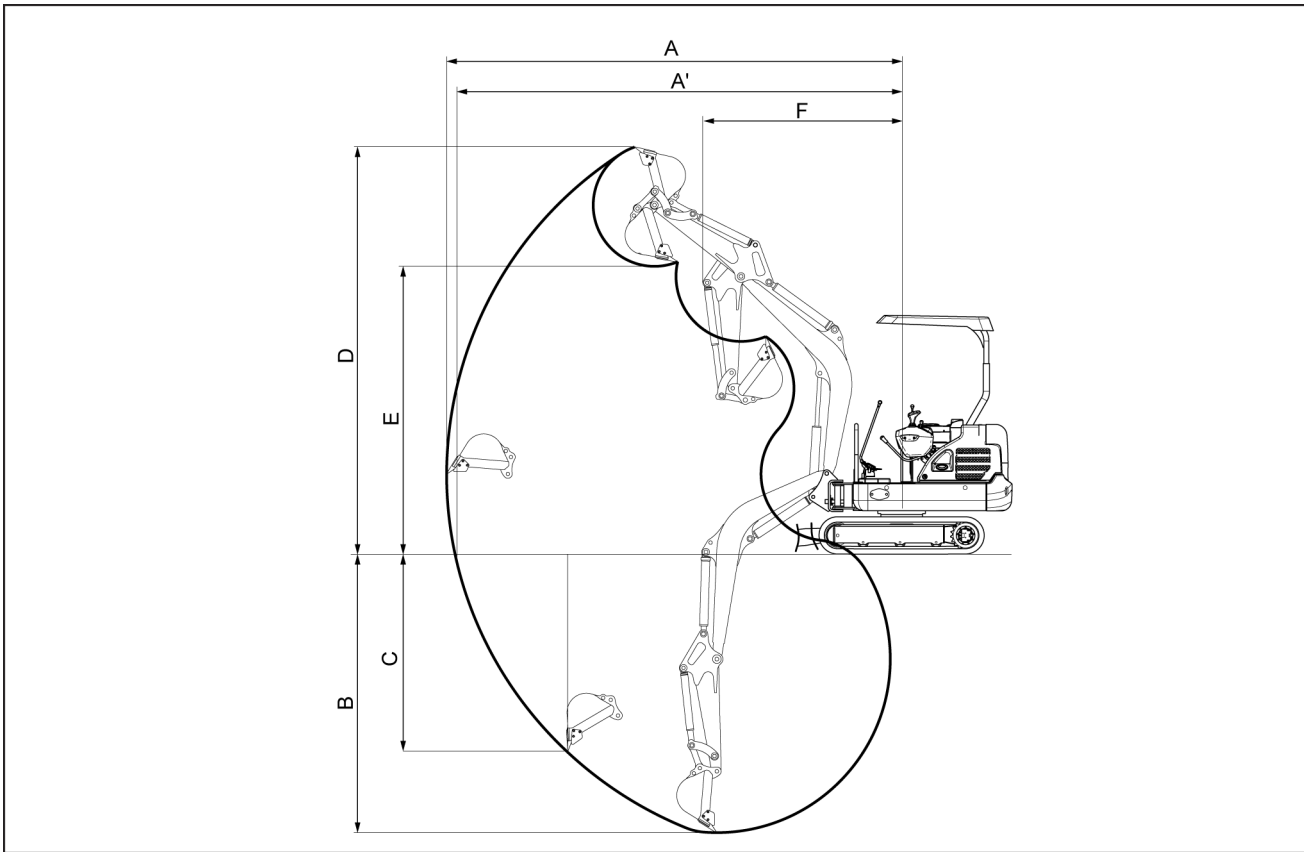

SMIL17MEX0036FA 3

(A) Maximum digging reach		3970 mm (156.3 in)
(A') Maximum digging reach on ground		3880 mm (152.8 in)
(B) Maximum digging depth		2250 mm (88.6 in)
(C) Maximum vertical wall digging depth		1785 mm (70.3 in)
(D) Maximum digging height		3670 mm (144.5 in)
(E) Maximum dumping height		2550 mm (100.4 in)
(F) Minimum swing radius		1615 mm (63.6 in)
Boom swing radius (left-hand/right-hand)		60° / 60°
Bucket digging force	SAE	13.1 kN (2945.0 lb)
	ISO	15.1 kN (3394.6 lb)
Arm crowd force	SAE	9 kN (2023.3 lb)
	ISO	9.4 kN (2113.2 lb)

Boom length: **1.8 m (70.9 in)**

Arm length: **0.96 m (37.8 in)**

With boom swing post

Torque - Special torque settings

Component		Bolt size	Tightening torque
Engine	Engine mounting bolt (engine bracket)	M10 × 1.25	96.3 – 155.9 N·m (71.0 – 115.0 lb ft)
	Engine mounting bolt (bracket frame)	M12 × 1.75	105.9 – 135.2 N·m (78.1 – 99.7 lb ft)
	Radiator mounting bolt, nut	M10 × 1.5	54.0 – 81.3 N·m (39.8 – 60.0 lb ft)
	Coupling mounting bolt	M10 × 1.5	54.0 – 81.3 N·m (39.8 – 60.0 lb ft)
Hydraulic system	Main pump mounting bolt	M12 × 1.75	96.3 – 155.9 N·m (71.0 – 115.0 lb ft)
	Main control valve mounting bolt	M10 × 1.5	54.0 – 81.3 N·m (39.8 – 60.0 lb ft)
	Fuel tank mounting bolt	M10 × 1.5	54.0 – 81.3 N·m (39.8 – 60.0 lb ft)
	Hydraulic oil tank mounting bolt	M10 × 1.5	54.0 – 81.3 N·m (39.8 – 60.0 lb ft)
	Hydraulic swivel mounting bolt, nut	M10 × 1.5	54.0 – 81.3 N·m (39.8 – 60.0 lb ft)
Power train system	Swing motor mounting bolt	M12 × 1.75	96.3 – 155.9 N·m (71.0 – 115.0 lb ft)
	Swing bearing upper mounting bolt	M12 × 1.75	96.3 – 155.9 N·m (71.0 – 115.0 lb ft)
	Swing bearing lower mounting bolt	M12 × 1.75	96.3 – 155.9 N·m (71.0 – 115.0 lb ft)
	Travel motor mounting bolt	M10 × 1.5	54.2 – 81.3 N·m (40.0 – 60.0 lb ft)
	Sprocket mounting bolt	M10 × 1.5	60.7 – 74.6 N·m (44.8 – 55.0 lb ft)
Under carriage	Track roller mounting bolt	M12 × 1.75	108.9 – 132.5 N·m (80.3 – 97.7 lb ft)
Others	Counterweight mounting bolt	M16 × 2.0	247.4 – 335.6 N·m (182.5 – 247.5 lb ft)
	Canopy mounting bolt, nut	M12 × 1.75	96.1 – 155.0 N·m (70.9 – 114.3 lb ft)
	Operator's seat mounting bolt	M8 × 1.25	10.6 – 12.5 N·m (7.8 – 9.2 lb ft)

Basic instructions - Shop and assembly

Shimming

For each adjustment operation, select adjusting shims and measure the adjusting shims individually using a micrometer, then add up the recorded values. Do not rely on measuring the entire shimming set, which may be incorrect, or the rated value shown on each shim.

Rotating shaft seals

For correct rotating shaft seal installation, proceed as follows:

1. Before assembly, allow the seal to soak in the oil it will be sealing for at least thirty minutes.
2. Thoroughly clean the shaft and check that the working surface on the shaft is not damaged.
3. Position the sealing lip facing the fluid.

NOTE: *With hydrodynamic lips, take into consideration the shaft rotation direction and position the grooves so that they will move the fluid towards the inner side of the seal.*

4. Coat the sealing lip with a thin layer of lubricant (use oil rather than grease). Fill the gap between the sealing lip and the dust lip on double lip seals with grease.
5. Insert the seal in its seat and press down using a flat punch or seal installation tool. Do not tap the seal with a hammer or mallet.
6. While you insert the seal, check that the seal is perpendicular to the seat. When the seal settles, make sure that the seal makes contact with the thrust element, if required.
7. To prevent damage to the seal lip on the shaft, position a protective guard during installation operations.

O-ring seals

Lubricate the O-ring seals before you insert them in the seats. This will prevent the O-ring seals from overturning and twisting, which would jeopardize sealing efficiency.

Sealing compounds

Apply a sealing compound on the mating surfaces when specified by the procedure. Before you apply the sealing compound, prepare the surfaces as directed by the product container.

Spare parts

Only use CNH Original Parts or CASE CONSTRUCTION Original Parts.

Only genuine spare parts guarantee the same quality, duration, and safety as original parts, as they are the same parts that are assembled during standard production. Only CNH Original Parts or CASE CONSTRUCTION Original Parts can offer this guarantee.

When ordering spare parts, always provide the following information:

- Machine model (commercial name) and Product Identification Number (PIN)
- Part number of the ordered part, which can be found in the parts catalog

Protecting the electronic and/or electrical systems during charging and welding

To avoid damage to the electronic and/or electrical systems, always observe the following practices:

1. Never make or break any of the charging circuit connections when the engine is running, including the battery connections.
2. Never short any of the charging components to ground.
3. Always disconnect the ground cable from the battery before arc welding on the machine or on any machine attachment.
 - Position the welder ground clamp as close to the welding area as possible.
 - If you weld in close proximity to a computer module, then you should remove the module from the machine.
 - Never allow welding cables to lie on, near, or across any electrical wiring or electronic component while you weld.
4. Always disconnect the negative cable from the battery when charging the battery in the machine with a battery charger.

NOTICE: *If you must weld on the unit, you must disconnect the battery ground cable from the machine battery. The electronic monitoring system and charging system will be damaged if this is not done.*

5. Remove the battery ground cable. Reconnect the cable when you complete welding.

WARNING

Battery acid causes burns. Batteries contain sulfuric acid.

Avoid contact with skin, eyes or clothing. Antidote (external): Flush with water. Antidote (eyes): flush with water for 15 minutes and seek medical attention immediately. Antidote (internal): Drink large quantities of water or milk. Do not induce vomiting. Seek medical attention immediately. Failure to comply could result in death or serious injury.

W0111A

Special tools

The special tools that CASE CONSTRUCTION suggests and illustrate in this manual have been specifically researched and designed for use with CASE CONSTRUCTION machines. The special tools are essential for reliable repair operations. The special tools are accurately built and rigorously tested to offer efficient and long-lasting operation.

By using these tools, repair personnel will benefit from:

- Operating in optimal technical conditions
- Obtaining the best results
- Saving time and effort
- Working in safe conditions

Machine specifications

Engine

Model	Mitsubishi L3E
Type	4-cycle vertical overhead valve, diesel fuel
Cooling method	Water cooling
Number of cylinders and arrangement	3 cylinders, in-line
Firing order	1 - 3 - 2
Combustion chamber type	Swirl chamber type
Cylinder bore x stroke	76 mm (2.99 in) x 70 mm (2.76 in)
Piston displacement	952 cm³ (58.1 in³)
Compression ratio	23 : 1
Rated gross horse power (SAE J1995)	12.5 kW (17.0 Hp) at 2300 RPM
Maximum torque at 1600 RPM	52.9 N·m (39 lb ft)
Engine oil quantity	4.2 L (1.1 US gal)
Dry weight	75 kg (165 lb)
High idling speed	2400 – 2500 RPM
Low idling speed	1640 – 1660 RPM
Rated fuel consumption	208 g/Hp·hr at 2300 RPM (279 g/kW·hr at 2300 RPM)
Starting motor	12 V, 1.7 kW
Alternator	12 V, 40 A
Battery	1 x 12 V x 80 A·h

Main pump

Type	Variable displacement tandem axis piston pumps
Capacity	2 x 7.4 cm³/rev (0.5 in³/rev)
Rated oil flow	2 x 17 L/min (4.5 US gpm)
Rated speed	2300 RPM

Gear pump

Type	Fixed displacement gear pump single stage
Capacity	4.5 – 2.7 cm³/rev (0.3 – 0.2 in³/rev)
Rated oil flow	10.4 – 6.2 L/min (2.7 – 1.6 US gpm)

Main control valve

Type	Sectional, 9 spools (12 blocks)
Operating method	Hydraulic pilot system
Main relief valve pressure	20615 kPa (2990 psi)
Overload relief valve pressure	22546 kPa (3270 psi)

Swing motor

Type	Fixed displacement axial piston motor
Capacity	18.1 cm³/rev (1.1 in³/rev)
Relief pressure	16203 kPa (2350 psi)
Reduction gear type	1 - stage planetary

Travel motor

Type	Variable displacement axial piston motor
Relief pressure	20615 kPa (2990 psi)
Reduction gear type	2-stage planetary

Cylinder

Boom cylinder	Bore diameter x Rod diameter x Stroke	Ø 60 mm (2.4 in) x Ø 40 mm (1.6 in) x 465 mm (18.3 in)
	Cushion	Extend only
Arm cylinder	Bore diameter x Rod diameter x Stroke	Ø 60 mm (2.4 in) x Ø 40 mm (1.6 in) x 400 mm (15.7 in)
	Cushion	-
Bucket cylinder	Bore diameter x Rod diameter x Stroke	Ø 55 mm (2.2 in) x Ø 35 mm (1.4 in) x 345 mm (13.6 in)
	Cushion	-
Boom swing cylinder	Bore diameter x Rod diameter x Stroke	Ø 55 mm (2.2 in) x Ø 30 mm (1.2 in) x 355 mm (14.0 in)
	Cushion	-
Dozer cylinder	Bore diameter x Rod diameter x Stroke	Ø 65 mm (2.6 in) x Ø 30 mm (1.2 in) x 93 mm (3.7 in)
	Cushion	-

NOTE: discoloration of cylinder rod can occur when the friction reduction additive of lubrication oil spreads on the rod surface.

Discoloration does not cause any harmful effect on the cylinder performance.

Types of shoes – Rubber track

Shoe width	230 mm (9.1 in)
Ground pressure	27.03 kPa (3.92 psi)
Overall width	1250 mm (49.2 in)

Number of rollers and shoes on each side

Track rollers	3
---------------	---

Weights

Machine

Operating weight – Cab version (*)	1890 kg (4167 lb)
Operating weight – Canopy version (**)	1720 kg (3792 lb)

Components

Upperstructure assembly	940 kg (2072 lb)
Main frame weld assembly	230 kg (507 lb)
Engine assembly	75 kg (165 lb)
Main pump assembly	17 kg (37 lb)
Main control valve assembly	25 kg (55 lb)
Swing motor assembly	23 kg (51 lb)
Hydraulic oil tank assembly	20 kg (44 lb)
Fuel tank assembly	15 kg (33 lb)
Boom swing post	35 kg (77 lb)
Counterweight	60 kg (132 lb)
Canopy assembly	47 kg (104 lb)
Front guard	12 kg (26 lb)
Lower chassis assembly	530 kg (1168 lb)
Track frame weld assembly	150 kg (331 lb)
Swing bearing	20 kg (44 lb)
Travel motor assembly	18 kg (40 lb)
Turning joint	20 kg (44 lb)
Track recoil spring	11 kg (24 lb)
Idler	15 kg (33 lb)
Track roller	3 kg (7 lb)
Sprocket	4 kg (9 lb)
Rubber track (230 mm (9.1 in))	66 kg (146 lb)
Dozer blade assembly	60 kg (132 lb)
Front attachment assembly (1.8 m (70.9 in) boom, 0.96 m (37.8 in) arm, 0.04 m³ (0.05 yd³) SAE heaped bucket)	200 kg (441 lb)
1.8 m (70.9 in) boom assembly	65 kg (143 lb)
0.96 m (37.8 in) arm assembly	30 kg (66 lb)
0.04 m³ (0.05 yd³) SAE heaped bucket	40 kg (88 lb)
Boom cylinder assembly	17 kg (37 lb)
Arm cylinder assembly	15 kg (33 lb)
Bucket cylinder assembly	11 kg (24 lb)
Bucket control link assembly	10 kg (22 lb)
Dozer cylinder assembly	11 kg (24 lb)
Boom swing cylinder assembly	11 kg (24 lb)
Extension cylinder assembly	8 kg (18 lb)

(*) Cab, boom, arm, bucket, lubricant, coolant, full fuel and hydraulic oil, without quick coupler system, rubber track. Weight tolerance: $\pm 3\%$.

(**) Canopy, boom, arm, bucket, lubricant, coolant, full fuel and hydraulic oil, without quick coupler system, rubber track. Weight tolerance: $\pm 3\%$.

Dimensions

Cab version

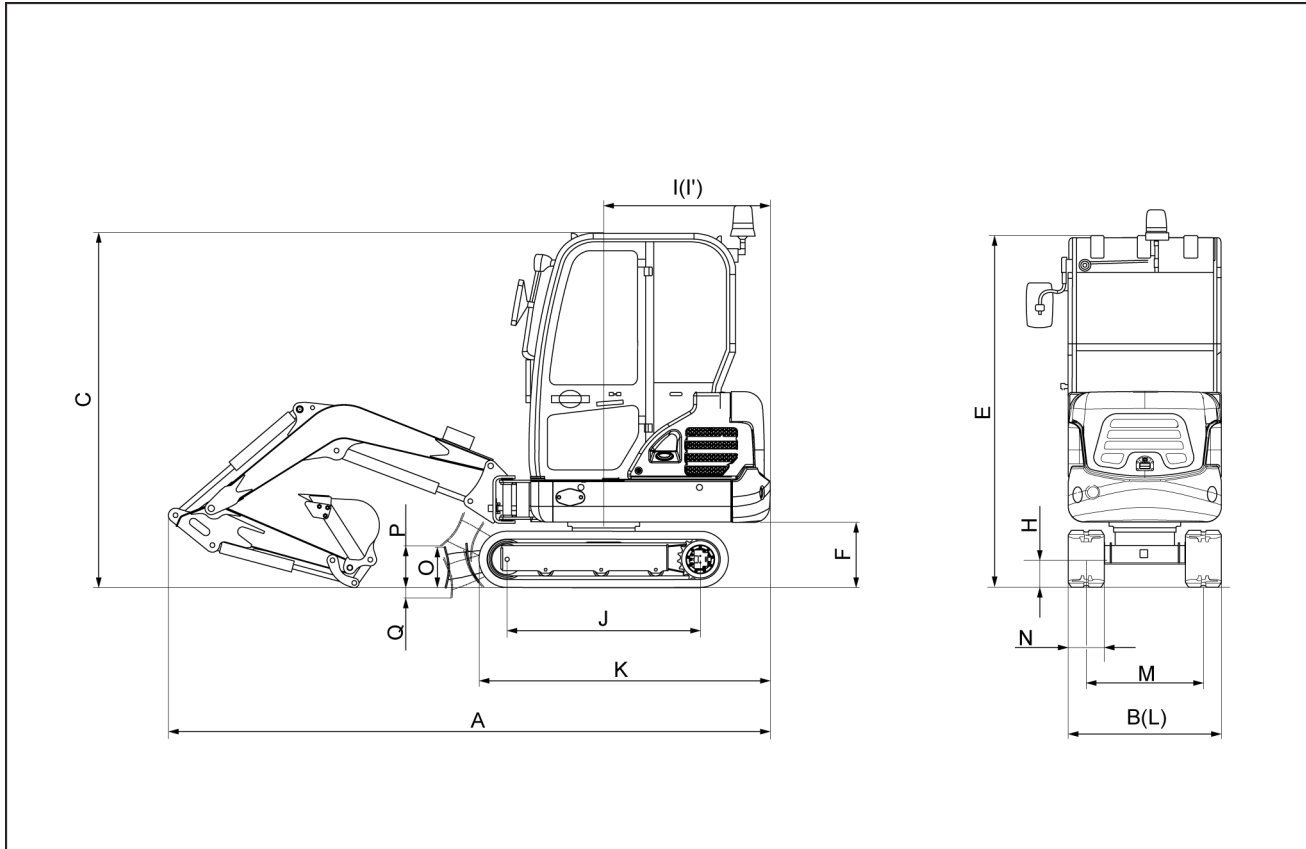

SMIL17MEX0035FA 1

(A) Overall length	3840 mm (151.2 in)
(B) Overall width, with 230 mm (9.1 in) shoe (extension track)	980 – 1250 mm (38.6 – 49.2 in)
(C) Overall height	2300 mm (90.6 in)
(E) Overall height of cab	2300 mm (90.6 in)
(F) Ground clearance of counterweight	415 mm (16.3 in)
(H) Minimum ground clearance	150 mm (5.9 in)
(I) Rear-end distance	1065 mm (41.9 in)
(I') Rear-end swing radius	1065 mm (41.9 in)
(J) Distance between tumbler	1230 mm (48.4 in)
(K) Undercarriage length	1590 mm (62.6 in)
(L) Undercarriage width (extension track)	980 – 1250 mm (38.6 – 49.2 in)
(M) Track gauge (extension track)	750 – 1020 mm (29.5 – 40.2 in)
(N) Track shoe width, standard	230 mm (9.1 in)
(O) Height of blade	250 mm (9.8 in)
(P) Ground clearance of blade up	170 mm (6.7 in)
(Q) Depth of blade down	240 mm (9.4 in)

Boom length: **1.8 m (70.9 in)**

Arm length: **0.96 m (37.8 in)**

With boom swing post

Canopy version

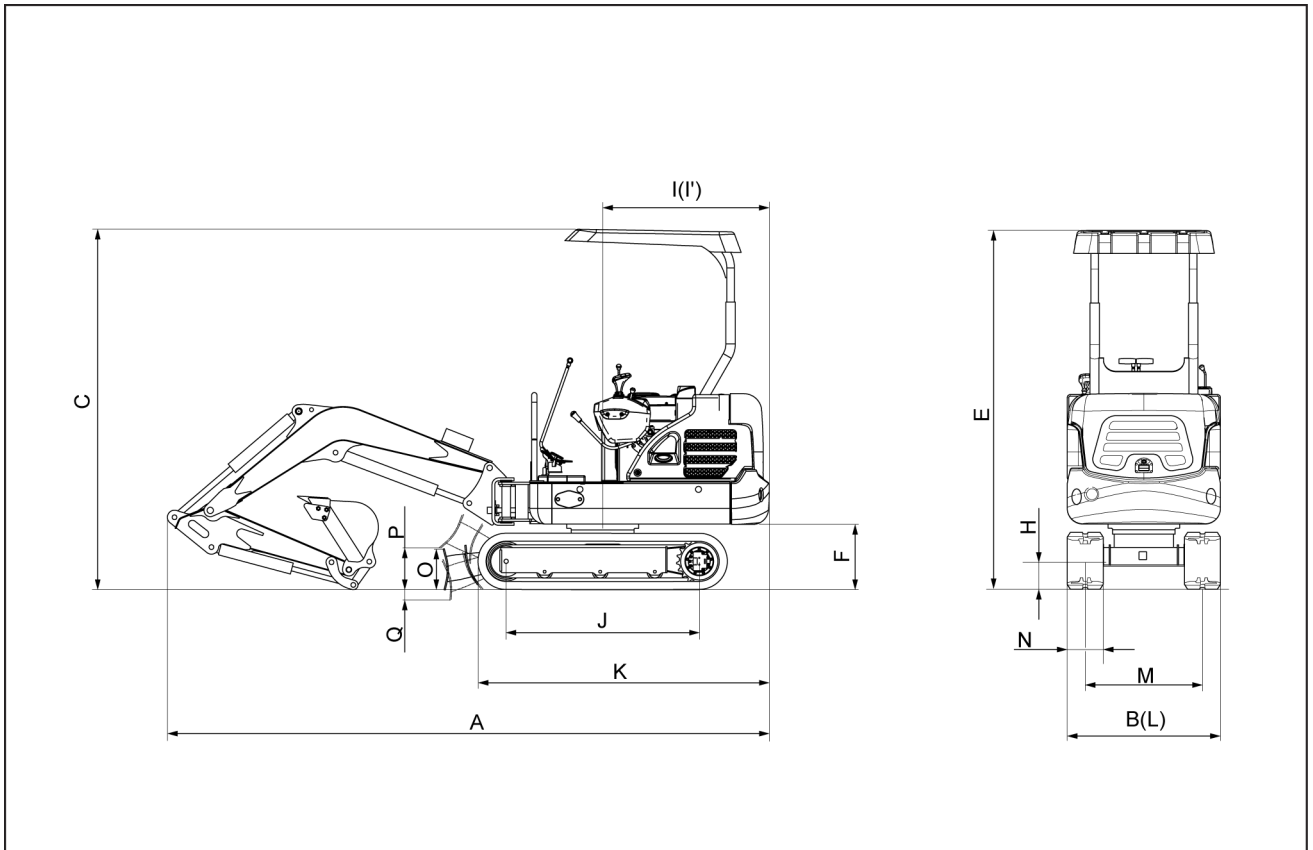

SMIL17MEX0034FA 2

(A) Overall length	3840 mm (151.2 in)
(B) Overall width, with 230 mm (9.1 in) shoe (extension track)	980 – 1250 mm (38.6 – 49.2 in)
(C) Overall height	2300 mm (90.6 in)
(E) Overall height of cab	2300 mm (90.6 in)
(F) Ground clearance of counterweight	415 mm (16.3 in)
(H) Minimum ground clearance	150 mm (5.9 in)
(I) Rear-end distance	1065 mm (41.9 in)
(I') Rear-end swing radius	1065 mm (41.9 in)
(J) Distance between tumblers	1230 mm (48.4 in)
(K) Undercarriage length	1590 mm (62.6 in)
(L) Undercarriage width (extension track)	980 – 1250 mm (38.6 – 49.2 in)
(M) Track gauge (extension track)	750 – 1020 mm (29.5 – 40.2 in)
(N) Track shoe width, standard	230 mm (9.1 in)
(O) Height of blade	250 mm (9.8 in)
(P) Ground clearance of blade up	170 mm (6.7 in)
(Q) Depth of blade down	240 mm (9.4 in)

Boom length: **1.8 m (70.9 in)**

Arm length: **0.96 m (37.8 in)**

With boom swing post

Click on the image link below for the full version of the service manual

