

# 2100 and 2300 Series Combines

## Service Manual Don 7-69612

### Table of Contents

	Section	Pub. No.
<b>1 GENERAL</b>		
Loctite Product Chart		8-98902
Standard Torques.....	1001	8-71601
General Information and Torque Specifications .....	1010	7-62780
<b>2 ENGINE</b>		
<b>NOTE:</b> For Service and Overhaul procedures refer to your Engine Service Manual.		
<b>3 FUEL SYSTEM</b>		
<b>NOTE:</b> For Service and Overhaul procedures refer to your Engine Service Manual.		
<b>4 ELECTRICAL</b>		
Wiring Schematics and Troubleshooting 2100 European Combines .....	4002	7-63870
Wiring Schematics and Troubleshooting 2166 and 2188 Series - See Serial Number breaks on cover (Includes Poster Rac 7-68230).....	4002	7-68210
Wiring Schematics and Troubleshooting 2300 European Combines (Includes Poster Rac 7-85470) .....	4002	7-85460
Wiring Schematics and Troubleshooting 2365, 2366, 2388 Series - See Serial Number breaks on cover (Includes Poster Rac 7-94780).....	4002	7-94790
Starter Motor .....	4011	8-95970
Neutral Start Switch and Correct Starting Procedure using Auxiliary Batteries .....	4050	7-62440
Feeder Reverse Motor .....	4080	8-29250
Battery Servicing and Testing .....	4235	8-20291
Alternator.....	4240	7-62450
<b>5 STEERING</b>		
Steering Hand Pump .....	5020	7-62570
Steering Cylinders .....	5030	8-27581
Steering Axles - Except Power Guide .....	5040	7-63840
Steering Priority Valve .....	5080	7-62760
<b>6 TRANSMISSION</b>		
Hydrostatic Drive System Troubleshooting .....	6005	8-29301
Testing the Hydrostatic Drive System) .....	6012	7-63520
Foot-n-Inch Valve).....	6015	7-62870
Hydraulic Drive Pump Removal and Installation .....	6017	7-63740
Servicing the Hydrostatic Drive Pump (Eaton Series 1).....	6018	7-34820
Servicing the Hydrostatic Drive Motor - Single Speed .....	6030	7-34841
Hydrostatic Drive Motor - Two Speed .....	6031	8-27911
Hydrostatic Motor and Transmission - Removal and Installation .....	6035	7-64310
Transmission Service .....	6040	7-62700
Final Drive - Standard and Heavy Duty.....	6060	7-62560
PTO Removal and Installation.....	6065	7-37671
PTO Service - 2166.....	6070	8-29371
PTO Service - 2188.....	6071	8-29382

**NOTE:** Information contained in this Manual may cover features that are not available in all markets worldwide.

<b>7 BRAKES</b>		
Brake Assemblies .....	7010	7-62540
Master Brake Valve.....	7020	7-62550
European Park Brake.....	7030	7-63790
<b>8 HYDRAULICS</b>		
Accumulator .....	8005	7-63230
Hydraulic Schematics and Troubleshooting 2100 Series.....	8011	7-63980
Hydraulic Schematics and Troubleshooting 2100 Series - See Serial Number Breaks on Section Cover (Includes Poster Rac 7-68240) .....	8011	7-68190
Hydraulic Schematics and Troubleshooting 2300 Series (Includes Poster Rac 7-85430) .....	8011	7-85421
Pressure Regulator Valve .....	8015	7-62830
Auxiliary Gear Pump and PFC Pump .....	8020	7-62920
Main Hydraulic Valve Stack .....	8030	7-62930
Separator Clutch and Unloading Auger Clutch Valves .....	8050	7-62720
Separator Drive Test and Troubleshooting (2188).....	8051	7-38491
Hydraulic Cylinders .....	8060	8-27620
Reel Drive Valve .....	8080	7-62840
<b>9 CHASSIS</b>		
Air Conditioning Troubleshooting - Visual and Operating .....	9010	7-63300
Air Conditioning Troubleshooting - 2300 Series See Serial Numbers Breaks on Section Cover.....	9010	7-93030
Air Conditioning System Gauges and Testing - For Systems with R-134a Refrigerant.....	9020	7-63310
Air Conditioning System Gauges and Testing - For Systems with R-134a Refrigerant - See Serial Numbers Breaks on Section Cover (Includes Poster Rac 7-93040) .....	9020	7-93050
Air Conditioning System Service - For Systems with R-134a Refrigerant) .....	9030	7-63320
Air Conditioning Components Service - For Systems with R-134a Refrigerant.....	9040	7-63330
Separator Drive Jackshaft.....	9101	7-62910
Rotor Drive .....	9102	7-63170
Rotor Gearbox .....	9103	7-63200
Feeder and Cleaning Fan Gearbox .....	9105	7-63800
Cleaning Fan Drive .....	9107	7-63890
Elevator Drive Jackshaft .....	9109	7-64050
Inclined Delivery Auger .....	9110	8-29510
Discharge Beater .....	9111	7-64100
Unloader Auger System.....	9117	7-63510
Field Tracker .....	9120	7-38450
Cross-Flow Fan.....	9121	7-38790
Straw Chopper Gearbox .....	9125	7-63260
Adjustable Concaves .....	9128	7-63860

# LOCTITE PRODUCT CHART

Product	Color	Similar Products	Gap (In Inches)	Strength (Steel/Steel)	Working Temperature Range-Farenheit	Fixture/Full Cure (Steel/Steel) Time	Primer	Description
#3	Dark Brown					24 hr	N/A	Form a Gasket (works with oil, fuel or grease) Pliable
80	Yellow					Fast	N/A	Weatherstrip Adhesive
123	Clear					N/A	N/A	Parts Cleaner Fluid
220	Blue	290	0.003	57/143 in lbs	-65 to +250	6 min/24 hrs	747	Wicking Threadlocker
221	Purple	222	0.005	75/44 in lbs	-65 to +300	2 min/24 hrs	747	Low Strength Threadlocker
222	Purple		0.005	53/30 in lbs	-65 to +300	20 min/24 hrs	764	Low Strength Threadlocker (Small Screws)
225	Brown	222	0.010	45/25 in lbs	-65 to +300	7 min/24 hrs	747	Low Strength Threadlocker
242	Blue		0.005	80/50 in lbs	-65 to +300	10 min/24 hrs	764	Medium Strength Threadlocker
262	Red	271	0.005	160/190 in lbs	-65 to +300	5 min/24 hrs	747	High Strength Threadlocker
270	Green	271	0.007	160/320 in lbs	-65 to +300	3 min/24 hrs	747	High Strength Threadlocker
271	Red	262	0.007	160/320 in lbs	-65 to +300	10 min/24 hrs	764	High Strength Threadlocker
272	Red	620	0.007	180/220 in lbs	-65 to +450	30 min/24 hrs	764	High Temperature, High Strength
275	Green	277	0.010	210/300 in lbs	-65 to +300	3 min/24 hrs	747	High Strength Threadlocker
277	Red		0.010	225/300 in lbs	-65 to +300	60 min/24 hrs	764	High Strength Threadlocker
290	Green		0.003	85/350 in lbs	-65 to +300	6 min/24 hrs	764	Wicking Threadlocker
*404	Clear	495	0.006	3200 psi	-65 to +180	30 sec/24 hrs	NA	Instant Adhesive
*406	Clear		0.004	3200 psi	-65 to +180	15 sec/24 hrs	N/A	Surface Insensitive Adhesive
*409	Clear	454	0.008	2500 psi	-65 to +180	50 sec/24 hrs	N/A	Gel Instant Adhesive
*414	Clear		0.006	2500 psi	-65 to +180	30 sec/24 hr	N/A	Instant Adhesive
*415	Clear	454	0.010	2500 psi	-65 to +180	50 sec/24 hrs	N/A	Gap Filling Instant Adhesive (Metals)
*416	Clear	454	0.010	2500 psi	-65 to +180	50 sec/24 hrs	N/A	Gap Filling Instant Adhesive (Plastics)
*420	Clear		0.002	2500 psi	-65 to +180	15 sec/24 hrs	N/A	Wicking Instant Adhesive
*422	Clear	454	0.020	2800 psi	-65 to +180	60 sec/24 hrs	N/A	Gap Filling Instant Adhesive
*430	Clear		0.005	2500 psi	-65 to +180	20 sec/24 hrs	N/A	Metal Bonding Adhesive
*445	White/Black		0.250	2000 psi	-65 to +180	5 min/24 hrs	N/A	Fast Setting 2 Part Epoxy
*454	Clear		0.010	3200 psi	-65 to +180	15 sec/24 hrs	N/A	Surface Insensitive Gen Instant Adhesive
*495	Clear		0.004	2500 psi	-65 to +180	20 sec/24 hrs	N/A	General Purpose Instant Adhesive
*496	Clear		0.005	2500 psi	-65 to +180	20 sec/24 hrs	N/A	Metal Bonding Adhesive
504	Brt Orange	515	0.030	750 psi	-65 to +300	90 min/24 hrs	None	Rigid Gasket Eliminator
509	Light Blue		0.020	750 psi	-65 to +320	6 hr/72 hrs	764	Flange Sealant
510	Red		0.020	1000 psi	-65 to +400	30 min/24 hrs	764	High Temperature, GAsket Eliminator
515	Purple		0.010	750 psi	-65 to +300	1 hr/24 hrs	764	Gasket Eliminator 515

# LOCTITE PRODUCT CHART

Product	Color	Similar Products	Gap (In Inches)	Strength (Steel/Steel)	Working Temperature Range-Farenheit	Fixture/Full Cure (Steel/Steel) Time	Primer	Description
518	Red	515	0.030	500psi	-65 to +300	1hr/24 hrs	764	Gasket Eliminator 518 for Aluminum
542	Brown	569	N/A	132/92 in lbs	-65 to +300	2 hr/24 hrs	747	Hydraulic Sealant
545	Purple		N/A	25/20 in lbs	-65 to +300	4 hr/24 hrs	747	Low Strength Pneumatic/Hydraulic Sealant
549	Orange	504	0.020	2500 psi	-65 to +300	2 hr/24 hrs	747	Instant Seal Plastic Gasket
554	Red	277	0.015	240/240 in lbs	-65 to +300	2 to 4 hrs/24 hrs	764	Refrigerant Sealant
567	White	592	N/A	500 psi	-65 to +400	4 hrs/24 hrs	764	Pipe Sealant for Stainless Steel
568	Orange	277	0.015	2500 psi	-65 to +300	12 hrs/24 hrs	764	Plastic Gasket
569	Brown	545	0.010	40/25 in lbs	-65 to +300	1 hr/24 hrs	764	Hydraulic Sealant
570	Brown	592	N/A	25/40 in lbs	-65 to +300	6 hrs/72 hrs	764	Steam Sealant
571	Brown	592	0.015	40/20 in lbs	-65 to +300	2 to 4 hrs/24 hrs	764	Pipe Sealant
572	White	578.575	N/A	80/27 in lbs	-65 to +300	24 hrs/72 hrs	None	Gasketing
592	White		0.020	500 psi	-65 to +400	4 hrs/72 hrs	736	Pipe Sealant with Teflon
593	Black		0.250	400 psi	-95 to +400	30 min/24 hrs	N/A	RTV Silicone
601	Green	609	0.005	3000 psi	-65 to +300	10 min/24 hrs	764	Current PIN #609
609	Green		0.005	3000 psi	-65 to +300	10 min/24 hrs	764	General Purpose Retaining Compound
620	Green	640	0.015	3000 psi	-65 to +450	30 min/24 hrs	747	High Temperature Retaining Compound
635	Green	680	0.010	4000 psi	-65 to +300	1 hr/24 hrs	747	High Strength Retaining Compound
638	Green	680	0.015	4100 psi	-65 to +300	10 min/24 hrs	747	High Strength Retaining Compound
640	Green	620	0.007	3000 psi	-65 to +400	1 hr/24 hrs	747	High Temperature Retaining Compound
660	Silver		0.020	3000 psi	-65 to +300	20 min/24 hrs	764	Quick Metal
675	Green	609	0.005	3000 psi	-65 to +300	20 min/24 hrs	747	General Purpose Retaining Compound
680	Green	635	0.015	4000 psi	-65 to +300	10 min/24 hrs	747	High Strength Retaining Compound
706	Clear	755	N/A	N/A	N/A	N/A	N/A	Cleaning Solvent
707	Amber		N/A	N/A	N/A	N/A	N/A	Activator for Structural Adhesives
736	Amber		N/A	N/A	N/A	N/A	N/A	Primer NF
738	Amber		N/A	N/A	N/A	N/A	N/A	Depend Activator
747	Yellow	N/A	N/A	N/A	N/A	N/A	N/A	Primer T
751	Clear		N/A	N/A	N/A	N/A	N/A	Activator for Structural Adhesives
755	Clear		N/A	N/A	N/A	N/A	N/A	Cleaning Solvent
764	Green		N/A	N/A	N/A	N/A	N/A	Primer N
767	Silver		N/A	N/A	-65 to +1600	N/A	N/A	Anti-Seize Lubricant



# Section 1001

## STANDARD TORQUE SPECIFICATIONS

CASE CORPORATION  
700 State Street  
Racine, WI 53404 U.S.A.

CASE CANADA CORPORATION  
3350 South Service Road  
Burlington, ON L7N 3M6 CANADA

Rac 8-71601

© 1994 Case Corporation  
Printed in U.S.A.  
Issued November, 1991

## TABLE OF CONTENTS

TORQUE SPECIFICATIONS - DECIMAL HARDWARE ..... 2

TORQUE SPECIFICATIONS - METRIC HARDWARE ..... 3

TORQUE SPECIFICATIONS - STEEL HYDRAULIC FITTINGS ..... 4

TORQUE SPECIFICATIONS - STEEL HYDRAULIC FITTINGS ..... 5

### TORQUE SPECIFICATIONS - DECIMAL HARDWARE

Use the torques in this chart when special torques are not given. These torques apply to fasteners with both UNC and UNF threads as received from suppliers dry, or when lubricated with engine oil. Not applicable if special graphities, molydisulfide greases, or other extreme pressure lubricants are used.

<b>Grade 5 Bolts, Nuts, and Studs</b>		
Size	Pound-Inches	Newton metres
5/16 inch	204 to 252	23 to 28
3/8 inch	270 to 336	30 to 37
Size	Pound-Feet	Newton metres
1/2 inch	80 to 96	109 to 130
5/8 inch	150 to 180	203 to 244
3/4 inch	270 to 336	365 to 435
7/8 inch	400 to 480	542 to 651
1 inch	500 to 636	727 to 944
1-1/8 inch	800 to 880	1085 to 1193
1-1/4 inch	1120 to 1280	1515 to 1697
1-3/8 inch	1460 to 1680	1980 to 2278
1-1/2 inch	1840 to 2280	2531 to 2985

<b>Grade 8 Bolts, Nuts, and Studs</b>		
Size	Pound-Inches	Newton metres
5/16 inch	288 to 348	33 to 39
3/8 inch	370 to 456	42 to 52
Size	Pound-Feet	Newton metres
1/2 inch	110 to 132	149 to 179
5/8 inch	220 to 264	298 to 358
3/4 inch	330 to 432	448 to 592
7/8 inch	600 to 720	814 to 976
1 inch	900 to 1080	1220 to 1465
1-1/8 inch	1280 to 1440	1736 to 1953
1-1/4 inch	1820 to 2000	2465 to 2712
1-3/8 inch	2380 to 2720	3227 to 3688
1-1/2 inch	3080 to 3560	4285 to 4927

**NOTE:** Use thick nuts with Grade 8 bolts.

## TORQUE SPECIFICATIONS - METRIC HARDWARE

Use the following torques when specifications are not given.

These values apply to fasteners with coarse threads as received from supplier, plated or unplated, or when lubricated with engine oil. These values do not apply if graphite or molydisulfide grease or oil is used.

<b>Grade 8.8 Bolts, Nuts, and Studs</b>		
		
Size	Pound-Inches	Newton metres
M5	60 to 72	7 to 8
M8	228 to 276	26 to 31
Size	Pound-Feet	Newton metres
M14	106 to 127	144 to 172
M20	320 to 380	434 to 515
M24	510 to 630	685 to 855
M30	920 to 1100	1250 to 1500
M36	1500 to 1950	2175 to 2600

<b>Grade 10.9 Bolts, Nuts, and Studs</b>		
		
Size	Pound-Inches	Newton metres
M5	84 to 96	9 to 11
M8	324 to 384	37 to 43
Size	Pound-Feet	Newton metres
M12	93 to 112	125 to 150
M16	230 to 280	310 to 380
M24	780 to 940	1050 to 1275
M36	2580 to 3090	3500 to 4200

### Grade 12.9 Bolts, Nuts, and Studs



Usually the torque values specified for grade 10.9 fasteners can be used satisfactorily on grade 12.9 fasteners.

## TORQUE SPECIFICATIONS - STEEL HYDRAULIC FITTINGS

Tube OD Hose ID	Thread Size	Pound- Inches	Newton metres
<b>37 Degree Flare Fitting</b>			
5/16 inch 7.9 mm	1/2-20	96 to 192	11 to 22
1/2 inch 12.7 mm	3/4-16	180 to 504	20 to 57
<b>37 Degree Flare Fitting</b>			
Tube OD Hose ID	Thread Size	Pound- Inches	Newton metres
7/8 inch 22.2 mm	1-3/16-12	60 to 100	81 to 135
1-1/4 inch 31.8 mm	1-5/8-12	125 to 165	169 to 223
1-3/4 inch 44.5 mm	2-1/8-12	220 to 250	285 to 308

Tube OD Hose ID	Thread Size	Pound- Inches	Newton metres
<b>Straight Threads with O-ring</b>			
1/4 inch 6.4 mm	7/16-20	144 to 228	16 to 26
5/16 inch 7.9 mm	1/2-20	192 to 300	22 to 34
3/8 inch 9.5 mm	9/16-18	300 to 480	34 to 54
1/2 inch 12.7 mm	3/4-16	540 to 804	57 to 91
Tube OD Hose ID	Thread Size	Pound- Inches	Newton metres
5/8 inch 15.9 mm	1-1/8-12	88 to 132	99 to 124
3/4 inch 19.0 mm	1-1/16-12	80 to 128	108 to 174
7/8 inch 22.2 mm	1-3/8-12	102 to 160	135 to 201
1.0 inch 25.4 mm	1-5/16-12	117 to 187	159 to 253
1-1/8 inch 31.8 mm	1-5/8-12	165 to 264	224 to 357
1-1/2 inch 38.1 mm	1-7/8-12	250 to 400	339 to 542

<b>Split Flange Mounting Bolts</b>		
Size	Pound- Inches	Newton metres
1/2-13	100 to 240	20 to 27
3/8-16	240 to 300	27 to 34
1/2-13	420 to 540	47 to 61
Size	Pound- Feet	Newton metres
1/2-13	55 to 65	74 to 88
5/8-11	140 to 150	190 to 203

## TORQUE SPECIFICATIONS - STEEL HYDRAULIC FITTINGS

Nom. SAE Dash Size	Tube OD	Thread Size	Pound-Inches	Newton metres	Thread Size	Pound-Inches	Newton metres
<b>O-ring Face Seal End</b>					<b>O-ring Boss End Fitting or Lock Nut</b>		
-4	1/4 inch 6.4 mm	9/16-18	120 to 144	14 to 16	7/16-20	204 to 240	23 to 27
-6	3/8 inch 9.5 mm	11/16-16	216 to 240	24 to 27	9/16-18	300 to 360	34 to 41
-8	1/2 inch 12.7 mm	13/16-16	384 to 480	43 to 54	3/4-16	540 to 600	61 to 68
					Thread Size	Pound-Inches	Newton metres
-10	5/8 inch 15.9 mm	1-14	552 to 672	62 to 76	7/8-14	600 to 65	68 to 88
Nom. SAE Dash Size	Tube OD	Thread Size	Pound-Inches	Newton metres	1-1/16-12	85 to 90	115 to 122
					1-3/16-12	95 to 100	120 to 136
-12	3/4 inch 19.1 mm	1-3/16-12	65 to 80	90 to 110	1-5/16-12	115 to 125	156 to 169
-14	7/8 inch 22.2 mm	1-3/16-12	65 to 80	90 to 110	1-5/8-12	150 to 160	203 to 217
-16	1.0 inch 25.4 mm	1-7/16-12	92 to 105	125 to 140	1-7/8-12	190 to 200	258 to 271
-20	1-1/4 inch 31.8 mm	1-11/16-12	125 to 140	170 to 190			
-24	1-1/2 inch 38.1 mm	2-12	150 to 180	200 to 254			

**NOTE:** The J I Case Company reserves the right to make improvements in design or changes in specifications at any time without incurring any obligation to install them on units previously sold.



# Section 1010

## FLUIDS AND LUBRICANTS

**CASE CORPORATION**  
700 State Street  
Racine, WI 53404 U.S.A.

**CASE CANADA CORPORATION**  
3350 South Service Road  
Burlington, ON L7N 3M6 CANADA

Rac 7-62780

© 1994 Case Corporation  
Printed in U.S.A.  
January, 1995

**1010**

## TABLE OF CONTENTS

ENGINE .....	3
COOLING SYSTEM .....	3
FUEL SYSTEM .....	3
TRANSMISSION .....	3
FINAL DRIVE .....	3
HYDRAULIC RESERVOIR .....	4
PTO HOUSING .....	4
FEEDER AND CLEANING FAN GEARCASE .....	4
LOWER UNLOADER GEAR CASE .....	4
ROTOR GEAR CASE .....	4
STRAW CHOPPER (IF EQUIPPED) .....	4

**NOTE:** The J I Case Company reserves the right to make improvements in design or changes in specifications at any time without incurring any obligation to install them on units previously sold.

## ENGINE

Oil Type.....	Case No. 1 Engine Oil
Oil Capacity - Without Filter Change	
2144 Combine .....	15 U.S. Quarts (14.3 Litres)
2166 Combine .....	20 U.S. Quarts (19 Litres)
2188 Combine .....	20 U.S. Quarts (19 Litres)
Oil Capacity - With Filter Change	
2144 Combine .....	16 U.S. Quarts (15 Litres)
2166 Combine .....	22 U.S. Quarts (21 Litres)
2188 Combine .....	22 U.S. Quarts (21 Litres)

**NOTE:** *DO NOT* put Performance Additives or other oil additive products in the engine crankcase.

## COOLING SYSTEM

Coolant Type.....	50 Percent Mixture of Water and Ethylene Glycol Solution
Coolant Capacity	
2144 Combine .....	36 U.S. Quarts (34 Litres)
2166 Combine .....	40 U.S. Quarts (37.8 Litres)
2188 Combine .....	40 U.S. Quarts (37.8 Litres)

**IMPORTANT:** *Use only heavy duty low silicate coolant. Automotive antifreeze purchased at local supply store outlets most likely is not low silicate and must not be used in Case engines.*

## FUEL SYSTEM

Fuel Type.....	ASTM D975 Grade 2-D Number 2 Diesel Fuel
Fuel Capacity	
2144 Combine .....	92.5 U.S. Gallons (350 Litres)
2166 Combine .....	92.5 U.S. Gallons (350 Litres)
2188 Combine .....	123 U.S. Gallons (466 Litres)

## TRANSMISSION

Oil Type.....	Case Hy-Tran Plus®
Oil Capacity.....	17 U.S. Quarts (16 Litres)

**NOTE:** *If brakes are removed from the transmission for service, an additional 1 U.S. Quart (0.95 Litre) per brake assembly must be added to the transmission.*

## FINAL DRIVE

Oil Type.....	Case Hy-Tran Plus®
Oil Capacity.....	13 U.S. Quarts (12.3 Litres)

## HYDRAULIC RESERVOIR

Oil Type ..... Case Hy-Tran Plus®  
Reservoir Capacity..... 10 U.S. Gallons (38 Litres)

## PTO HOUSING

Oil Type ..... Case Hy-Tran Plus®  
Oil Capacity ..... 14 U.S. Quarts (13.2 Litres)

## FEEDER AND CLEANING FAN GEAR CASE

Oil Type ..... Case 135H EP 85W-140 Gear Lubricant  
Oil Capacity ..... 2.75 U.S. Quarts (2.6 Litres)

## LOWER UNLOADER GEAR CASE

Oil Type ..... Case 135H EP 85W-140 Gear Lubricant  
Oil Capacity ..... 0.875 to 0.938 U.S. Quart (0.83 to 0.89 Litre)

## ROTOR GEAR CASE

Oil Type ..... Case Hy-Tran Plus®  
Oil Capacity ..... 4 U.S. Quarts (3.8 Litres)

## STRAW CHOPPER (IF EQUIPPED)

Oil Type ..... Case Hy-Tran Plus®  
Oil Capacity ..... 3.3 U.S. Quarts (3.1 Litres)

# LOCTITE PRODUCT CHART

Product	Color	Similar Products	Gap (In Inches)	Strength (Steel/Steel)	Working Temperature Range-Fahrenheit	Fixture/Full Cure (Steel/Steel) Time	Primer	Description
#3	Dark Brown					24 hr	N/A	Form a Gasket (works with oil, fuel or grease) Pliable
80	Yellow					Fast	N/A	Weatherstrip Adhesive
123	Clear					N/A	N/A	Parts Cleaner Fluid
220	Blue	290	0.003	57/143 in lbs	-65 to +250	6 min/24 hrs	747	Wicking Threadlocker
221	Purple	222	0.005	75/44 in lbs	-65 to +300	2 min/24 hrs	747	Low Strength Threadlocker
222	Purple		0.005	53/30 in lbs	-65 to +300	20 min/24 hrs	764	Low Strength Threadlocker (Small Screws)
225	Brown	222	0.010	45/25 in lbs	-65 to +300	7 min/24 hrs	747	Low Strength Threadlocker
242	Blue		0.005	80/50 in lbs	-65 to +300	10 min/24 hrs	764	Medium Strength Threadlocker
262	Red	271	0.005	160/190 in lbs	-65 to +300	5 min/24 hrs	747	High Strength Threadlocker
270	Green	271	0.007	160/320 in lbs	-65 to +300	3 min/24 hrs	747	High Strength Threadlocker
271	Red	262	0.007	160/320 in lbs	-65 to +300	10 min/24 hrs	764	High Strength Threadlocker
272	Red	620	0.007	180/220 in lbs	-65 to +450	30 min/24 hrs	764	High Temperature, High Strength
275	Green	277	0.010	210/300 in lbs	-65 to +300	3 min/24 hrs	747	High Strength Threadlocker
277	Red		0.010	225/300 in lbs	-65 to +300	60 min/24 hrs	764	High Strength Threadlocker
290	Green		0.003	85/350 in lbs	-65 to +300	6 min/24 hrs	764	Wicking Threadlocker
*404	Clear	495	0.006	3200 psi	-65 to +180	30 sec/24 hrs	NA	Instant Adhesive
*406	Clear		0.004	3200 psi	-65 to +180	15 sec/24 hrs	N/A	Surface Insensitive Adhesive
*409	Clear	454	0.008	2500 psi	-65 to +180	50 sec/24 hrs	N/A	Gel Instant Adhesive
*414	Clear		0.006	2500 psi	-65 to +180	30 sec/24 hr	N/A	Instant Adhesive
*415	Clear	454	0.010	2500 psi	-65 to +180	50 sec/24 hrs	N/A	Gap Filling Instant Adhesive (Metals)
*416	Clear	454	0.010	2500 psi	-65 to +180	50 sec/24 hrs	N/A	Gap Filling Instant Adhesive (Plastics)
*420	Clear		0.002	2500 psi	-65 to +180	15 sec/24 hrs	N/A	Wicking Instant Adhesive
*422	Clear	454	0.020	2800 psi	-65 to +180	60 sec/24 hrs	N/A	Gap Filling Instant Adhesive
*430	Clear		0.005	2500 psi	-65 to +180	20 sec/24 hrs	N/A	Metal Bonding Adhesive
*445	White/Black		0.250	2000 psi	-65 to +180	5 min/24 hrs	N/A	Fast Setting 2 Part Epoxy
*454	Clear		0.010	3200 psi	-65 to +180	15 sec/24 hrs	N/A	Surface Insensitive Gen Instant Adhesive
*495	Clear		0.004	2500 psi	-65 to +180	20 sec/24 hrs	N/A	General Purpose Instant Adhesive
*496	Clear		0.005	2500 psi	-65 to +180	20 sec/24 hrs	N/A	Metal Bonding Adhesive
504	Brit Orange	515	0.030	750 psi	-65 to +300	90 min/24 hrs	None	Rigid Gasket Eliminator
509	Light Blue		0.020	750 psi	-65 to +320	6 hr/72 hrs	764	Flange Sealant
510	Red		0.020	1000 psi	-65 to +400	30 min/24 hrs	764	High Temperature Gasket Eliminator
515	Purple		0.010	750 psi	-65 to +300	1 hr/24 hrs	764	Gasket Eliminator 515

Rac 8-99902 \* Products 404-496 (except for #445) are all instant adhesives (super glues) they differ mostly in viscosity

Printed in U.S.A.



# LOCTITE PRODUCT CHART

Product	Color	Similar Products	Gap (In Inches)	Strength (Steel/Steel)	Working Temperature Range-Fahrenheit	Fixture/Full Cure (Steel/Steel) Time	Primer	Description
518	Red	515	0.030	500psi	-65 to +300	1 hr/24 hrs	764	Gasket Eliminator 518 for Aluminum
542	Brown	569	N/A	132/92 in lbs	-65 to +300	2 hr/24 hrs	747	Hydraulic Sealant
545	Purple		N/A	25/20 in lbs	-65 to +300	4 hr/24 hrs	747	Low Strength Pneumatic/Hydraulic Sealant
549	Orange	504	0.020	2500 psi	-65 to +300	2 hr/24 hrs	747	Instant Seal Plastic Gasket
554	Red	277	0.015	240/240 in lbs	-65 to +300	2 to 4 hrs/24 hrs	764	Refrigerant Sealant
567	White	592	N/A	500 psi	-65 to +400	4 hrs/24 hrs	764	Pipe Sealant for Stainless Steel
568	Orange	277	0.015	2500 psi	-65 to +300	12 hrs/24 hrs	764	Plastic Gasket
569	Brown	545	0.010	40/25 in lbs	-65 to +300	1 hr/24 hrs	764	Hydraulic Sealant
570	Brown	592	N/A	25/40 in lbs	-65 to +300	6 hrs/72 hrs	764	Steam Sealant
571	Brown	592	0.015	40/20 in lbs	-65 to +300	2 to 4 hrs/24 hrs	764	Pipe Sealant
572	White	578.575	N/A	80/27 in lbs	-65 to +300	24 hrs/72 hrs	None	Gasketing
592	White		0.020	500 psi	-65 to +400	4 hrs/72 hrs	736	Pipe Sealant with Teflon
593	Black		0.250	400 psi	-95 to +400	30 min/24 hrs	N/A	RTV Silicone
601	Green	609	0.005	3000 psi	-65 to +300	10 min/24 hrs	764	Current PIN #609
609	Green		0.005	3000 psi	-65 to +300	10 min/24 hrs	764	General Purpose Retaining Compound
620	Green	640	0.015	3000 psi	-65 to +450	30 min/24 hrs	747	High Temperature Retaining Compound
635	Green	680	0.010	4000 psi	-65 to +300	1 hr/24 hrs	747	High Strength Retaining Compound
638	Green	680	0.015	4100 psi	-65 to +300	10 min/24 hrs	747	High Strength Retaining Compound
640	Green	620	0.007	3000 psi	-65 to +400	1 hr/24 hrs	747	High Temperature Retaining Compound
660	Silver		0.020	3000 psi	-65 to +300	20 min/24 hrs	764	Quick Metal
675	Green	609	0.005	3000 psi	-65 to +300	20 min/24 hrs	747	General Purpose Retaining Compound
680	Green	635	0.015	4000 psi	-65 to +300	10 min/24 hrs	747	High Strength Retaining Compound
706	Clear	755	N/A	N/A	N/A	N/A	N/A	Cleaning Solvent
707	Amber		N/A	N/A	N/A	N/A	N/A	Activator for Structural Adhesives
736	Amber		N/A	N/A	N/A	N/A	N/A	Primer NF
738	Amber		N/A	N/A	N/A	N/A	N/A	Depend Activator
747	Yellow	N/A	N/A	N/A	N/A	N/A	N/A	Primer T
751	Clear		N/A	N/A	N/A	N/A	N/A	Activator for Structural Adhesives
755	Clear		N/A	N/A	N/A	N/A	N/A	Cleaning Solvent
764	Green		N/A	N/A	N/A	N/A	N/A	Primer N
767	Silver		N/A	N/A	-65 to +1600	N/A	N/A	Anti-Seize Lubricant

# Section 2011

## AFTERCOOLER 6-830 Diesel Engine

**IMPORTANT:** *This engine was made using the metric measurement system. All measurements and checks must be made with metric tools to make sure of an accurate reading when inspecting parts.*

**CASE CORPORATION**  
700 State Street  
Racine, WI 53404 U.S.A.

**CASE CANADA CORPORATION**  
3350 South Service Road  
Burlington, ON L7N 3M6 CANADA

© 1994 Case Corporation

Rac 8-91702

January, 1991 (Revised December, 1994)

## TABLE OF CONTENTS

SPECIAL TOOLS .....	2
SPECIAL TORQUES .....	2
SERVICING THE AFTERCOOLER .....	3
Removal .....	3
Installation .....	4

## SPECIAL TOOLS

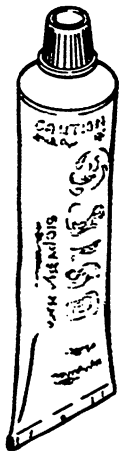

404L94

THREAD SEALANT WITH TEFLON - B17503 6ml TUBE



485L94

THREE BOND SILVER RTV SEALER  
J823494 - 3 oz TUBE

## SPECIAL TORQUES

Aftercooler Mounting Bolts .....	21 to 27 Nm
Crossover Tube Clamps.....	4 to 6 Nm

## SERVICING THE AFTERCOOLER Removal

### STEP 1

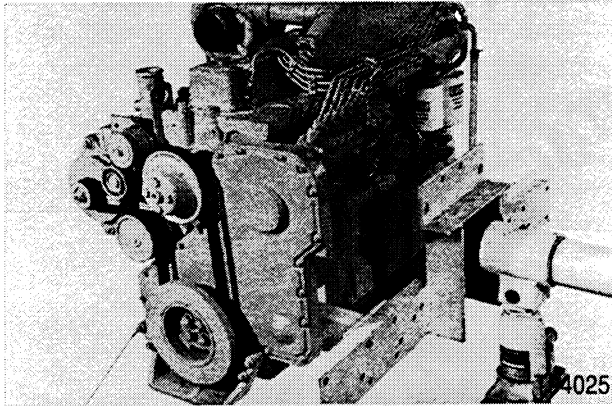

Case 6TA 830 engine.

### STEP 2

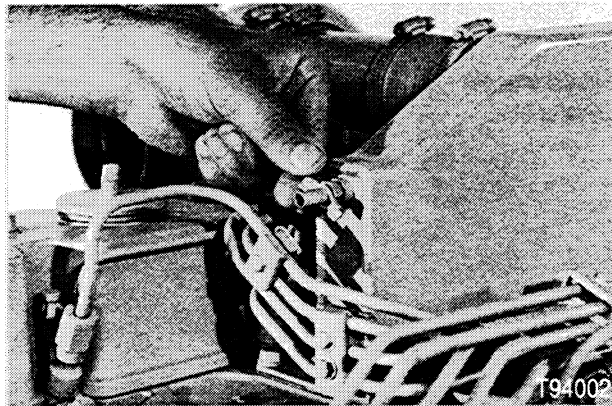

Drain the coolant from the engine. Open the air vent valve on the aftercooler to help drain the coolant.

### STEP 3

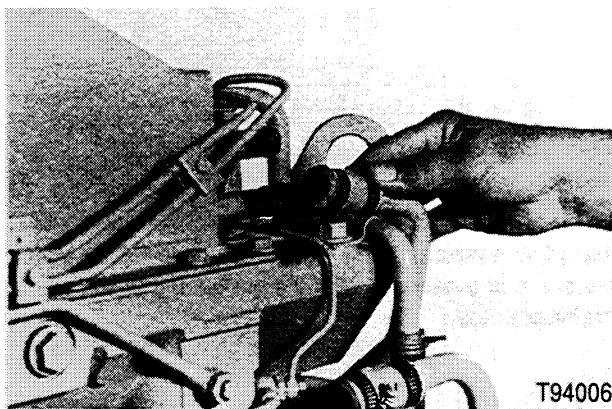

Remove all fuel lines and water hoses from the aftercooler.

### STEP 4

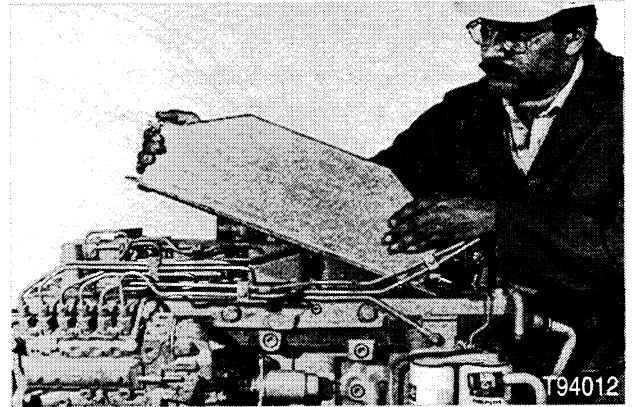

Remove the bolts and aftercooler. Discard the gasket. Clean the gasket surfaces. Inspect the housing and core for damage.

### STEP 5

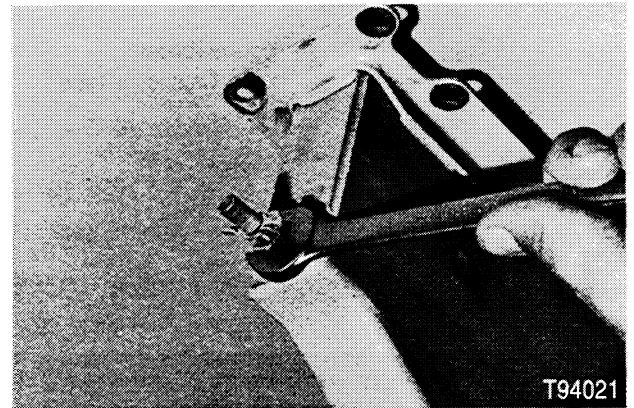

Remove the air vent valve from the aftercooler.

### STEP 6



Install a plug in the air vent valve and put a cap on one of the aftercooler water hose tube. Attach regulated air pressure to the other water hose tube. Pressurize the core to 206 kPa (2 bar) (30 PSI) and submerge the aftercooler in water. Inspect for any air leaks. If there leaks or damage, the aftercooler must be replaced.

### Installation

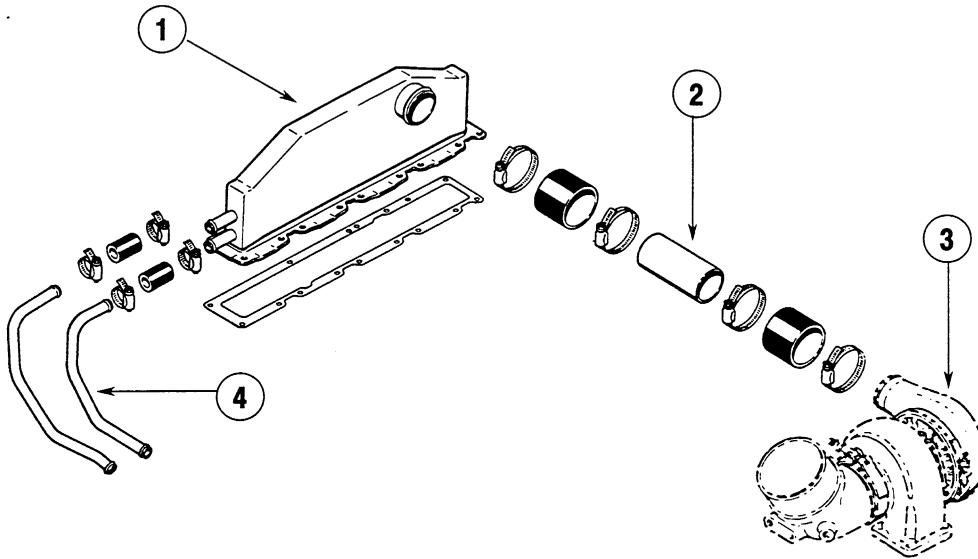

87L91

- 1. Aftercooler
- 2. Crossover Tube

- 3. Turbocharger
- 4. Water Line

### STEP 7

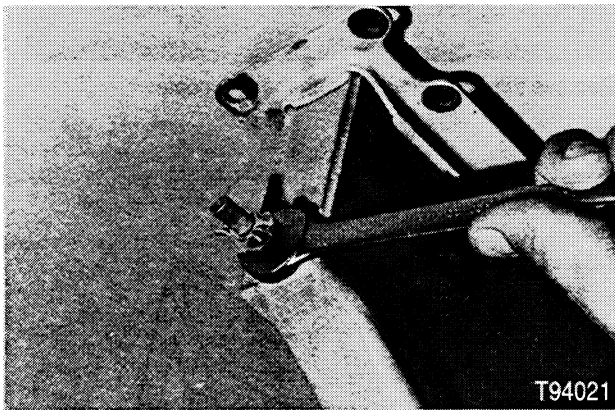

Apply teflon thread sealant to threads of air vent valve and install in the aftercooler.

### STEP 8

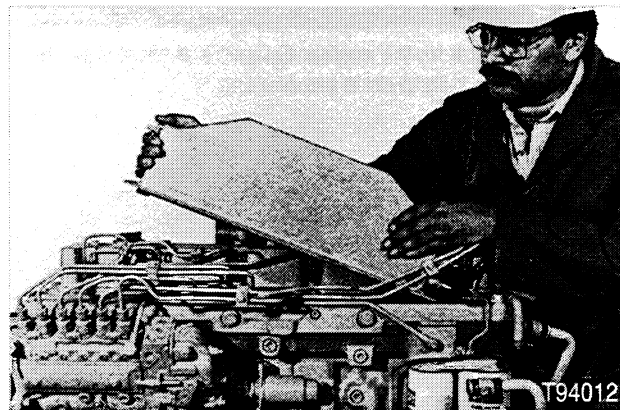

Apply a thin layer of Three Bond RTV Silver Sealer to both sides of a new gasket. Install the gasket and aftercooler on the cylinder head.



**STEP 9**

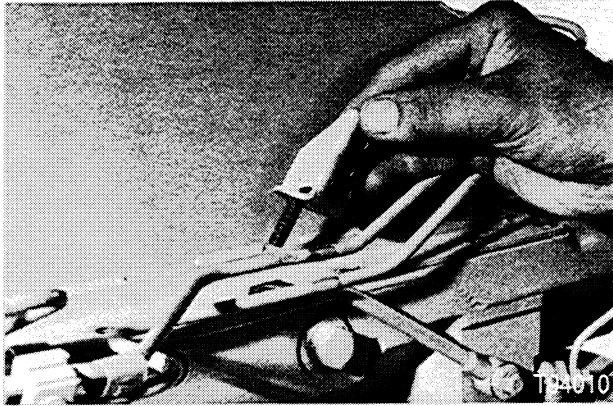

Apply Loctite liquid tefflon thread sealer on the injector line mounting bracket bolts. Install the injector line mounting brackets on the aftercooler.

**STEP 10**

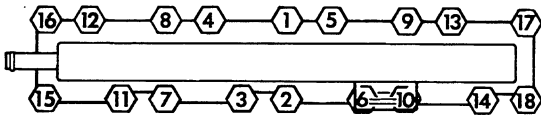

78L91

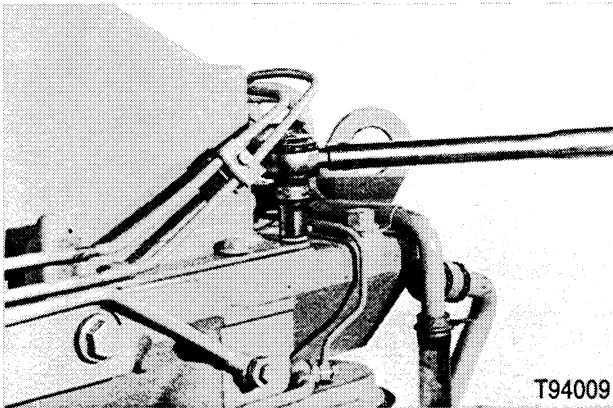

T94009

Apply Loctite liquid tefflon thread sealer to the remaining aftercooler bolts. Install the aftercooler mounting bolts and tighten to a torque of 21 to 27 Nm following the torque sequence shown above.

**STEP 11**

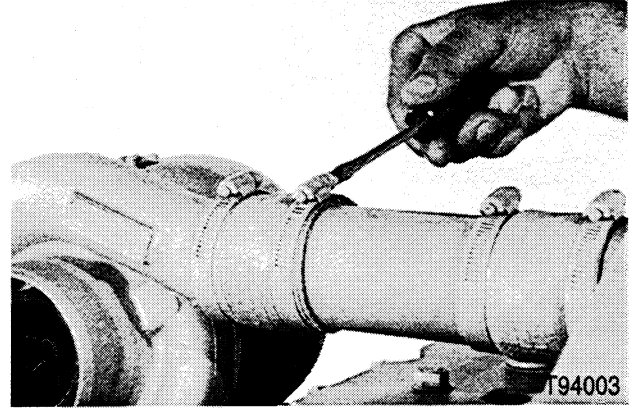

T94003

Install the crossover tube, injector tubes and water hoses on the aftercooler and turbocharger. Tighten the water hose clamps to a torque of 4 to 6 Nm.

**STEP 12**

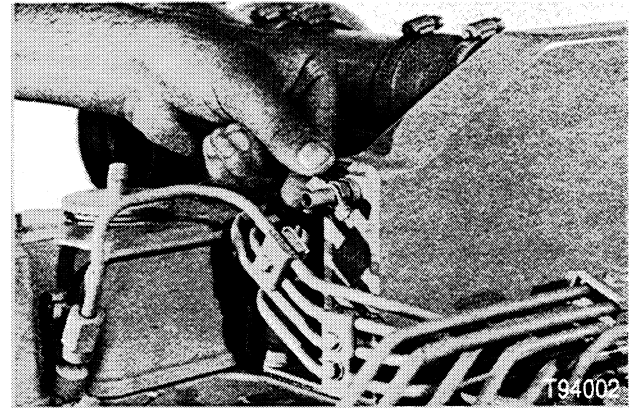

T94002

Fill the cooling system with coolant. Open the air vent valve to remove trapped air. Close the valve when coolant appears.

**STEP 13**

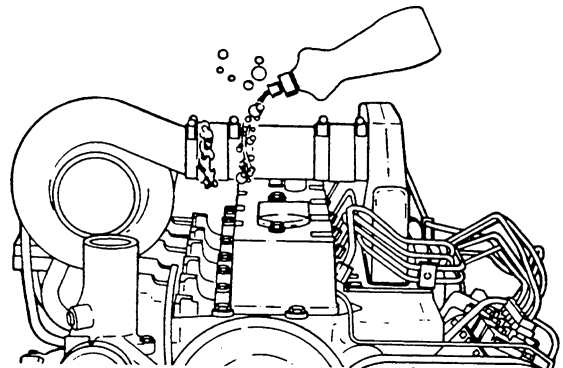

520L94

With the engine running, apply a liquid soap solution to the crossover tube, connections and manifold cover sealing surfaces to find air leaks. The leaks will create bubbles that are easier to detect.

**NOTE:** The J I Case Company reserves the right to make improvements in design or changes in specifications at any time without incurring any obligation to install them on units previously sold.



# Section

# 2403

2403

## SPECIFICATION DETAILS

### 6-830 Diesel Engine

**IMPORTANT:** *This engine was made using the metric measurement system. All measurements and checks must be made with metric tools to make sure of an accurate reading when inspecting parts.*

**CASE CORPORATION**  
700 State Street  
Racine, WI 53404 U.S.A.

**CASE CANADA CORPORATION**  
3350 South Service Road  
Burlington, ONL7N 3M6 CANADA

Rac 8-28425

© 1994 Case Corporation  
Printed in U.S.A.  
January, 1987 (Revised December, 1994)

## TABLE OF CONTENTS

RUN-IN INSTRUCTIONS .....	3
Engine Lubrication .....	3
Run-In Procedure for Rebuilt Engine .....	3
Run-In Procedure for Rebuilt Engines (with a Dynamometer) .....	3
Run-In Procedure for Rebuilt Engines (without a Dynamometer) .....	3
Run-In Procedure (Agriculture Equipment) .....	3
Run-In Procedure (Construction Equipment) .....	3
ENGINE SPECIFICATION DETAILS .....	4
Cylinder Block Prior to Engine Serial Number 44487830 .....	4
Cylinder Block Engine Serial Number 44487830 and After .....	4
Cylinder Sleeve Prior to Engine Serial Number 44487830 .....	4
Cylinder Sleeve Engine Serial Number 44487830 and After .....	4
Piston Pin .....	4
Piston .....	5
Piston .....	5
Cylinder Head .....	5
Lifters .....	5
Connecting Rod .....	6
Crankshaft .....	6
Camshaft .....	7
Turbocharger .....	7
Gear Train .....	7
Rocker Arm Assembly .....	7
Intake Valve .....	8
Exhaust Valve .....	8
Valve Springs .....	8
Oil Pressure Regulator Spring: .....	8
SPECIAL TORQUES .....	9

## RUN-IN INSTRUCTIONS

### Engine Lubrication

Fill the 6-830 engine crankcase with CC/SF, CD/SF, CE/SF or CF-4 service classification oil. Use the correct viscosity rating for the ambient air temperature. Install new oil filters after the engine is rebuilt.

Fill the 6T 830 and the 6TA 830 engine crankcase with CE/SF or CF-4 service classification oil. Use the correct viscosity rating for the ambient air temperature. Install new oil filters after the engine is rebuilt.

### Run-In Procedure for Rebuilt Engine

- Step 1 Disconnect the wire to the electric shut-off on the injection pump so that the engine will not start. Crank the engine for 30 seconds until there is oil pressure, then reconnect the wire.
- Step 2 Make sure the coolant level is correct.
- Step 3 Run the engine at 1000 RPM minimum load for 5 minutes and check for oil leaks.
- Step 4 Continue to check the oil pressure, coolant level and coolant temperature during run-in.

### Run-In Procedure for Rebuilt Engines (with a Dynamometer)

The following procedure must be followed when using a PTO dynamometer to Run-In the engine. The dynamometer will control the engine load at each speed and will remove stress on new parts during Run-In.

Continue to check the oil pressure, coolant level and coolant temperature.

STEP	TIME	ENGINE SPEED	DYNAMOMETER SCALE LOAD
1	5 Minutes	1000 RPM	50
2	5 Minutes	1100 RPM	1/2
3	5 Minutes	2200 RPM	Full

### Run-In Procedure for Rebuilt Engines (without a Dynamometer)

STEP	TIME	ENGINE SPEED	LOAD
1	5 Minutes	1000 RPM	No Load
2	5 Minutes	1100 RPM	Light Load
3	5 Minutes	2200 RPM	Full

### Run-In Procedure (Agriculture Equipment)

Use one gear lower than normal for the first 8 hours of field operation. DO NOT lug the engine for the next 12 hours. Move the lever to a lower gear to prevent lugging the engine. Do not lug the engine below the rated engine RPM during early hours of life.

### Run-In Procedure (Construction Equipment)

Operate the engine at full throttle with a normal load for the first 8 hours. Do not stall the converter or the hydraulics. Do not lug the engine below the Rated Engine RPM (Do not stall the engine more than 10 seconds).



Click on the image link below for the full version of the service manual

