

40 BLC
Feller Buncher
Service Manual

S406299

CASE

**40 BLC
FELLER/BUNCHER
SERVICE MANUAL
S-406299**

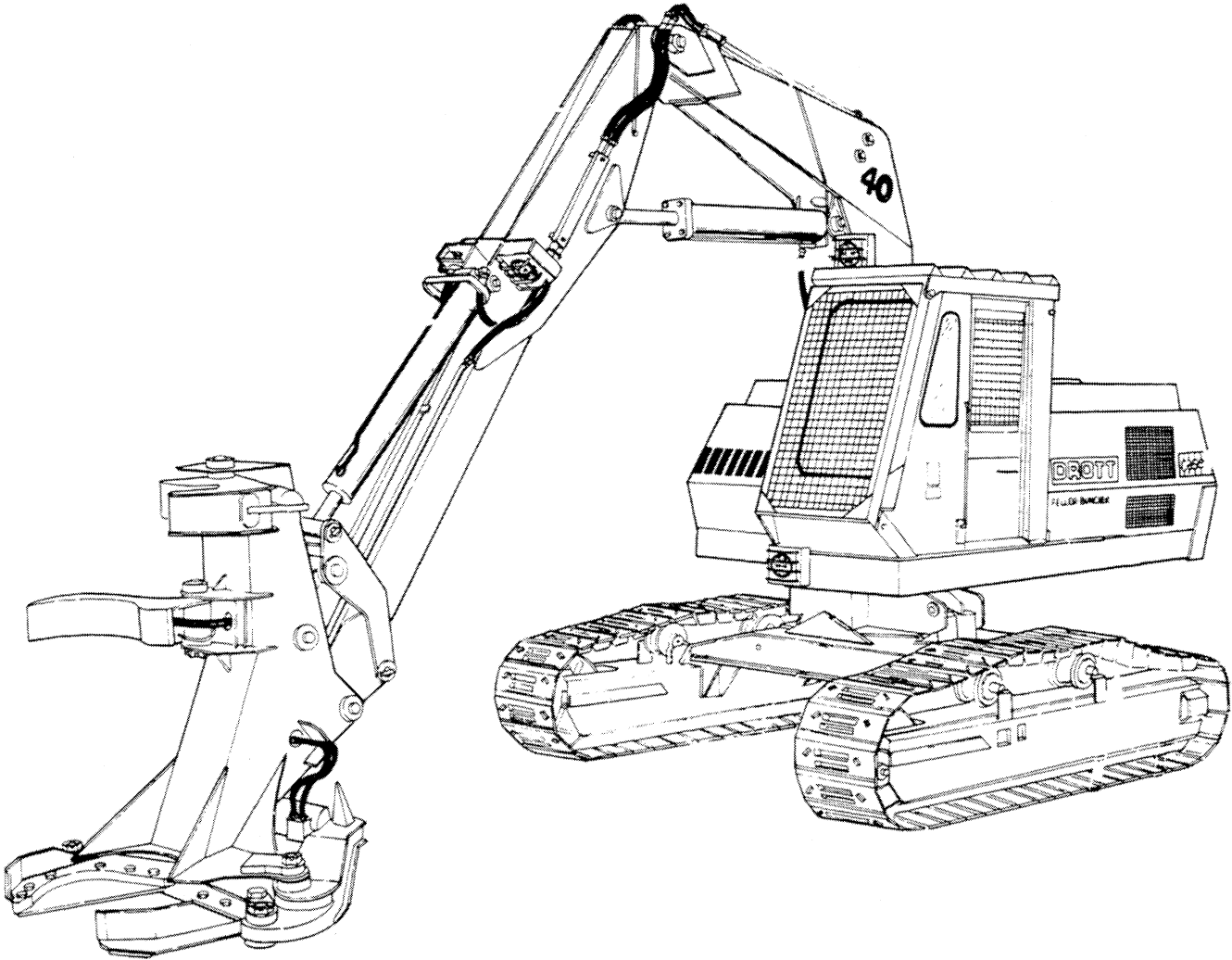

JICase

Drott Division
PO Box 1087 Wausau, WI 54401 U.S.A.

**Thank you for choosing
CasetractorManuals**

**Please click the following link to
download and purchase**

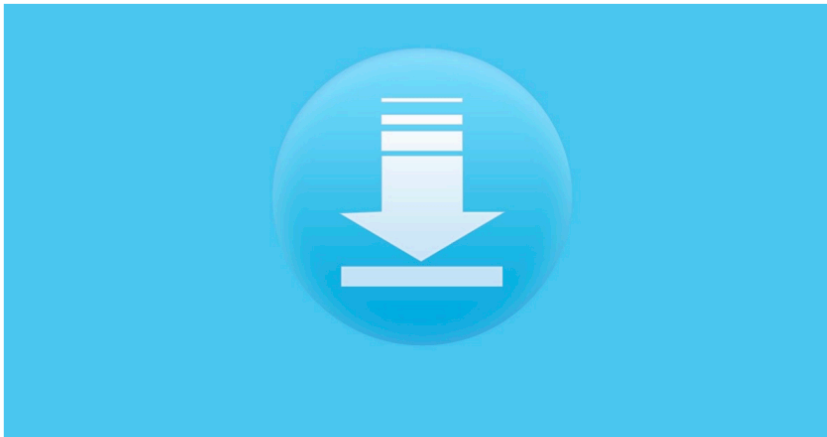

CONTENTS

GENERAL	
Index	2
Safety Precautions	3, 4
Introduction	5
Nomenclature, Description and Specifications	6-8
SECTION 1 - SCHEDULED PREVENTIVE MAINTENANCE	
Introduction	9
Hydraulic System Pressures	10
Component Capacities, Lubricants, and Fluids	11
Maintenance Chart	12, 13
Illustrated Listing of Grease Fittings	14, 15
Itemized Maintenance Instructions	16-23
SECTION 2 - MECHANICAL SYSTEM	
Undercarriage Components	24-32
Engine and Related Parts	32-35
Turntable Swing	35-40
Boom and Attachments	40-44
Control Linkages	45
SECTION 3 - ELECTRICAL SYSTEM	
Introduction	46
System Description and Wiring Harnesses	47-55
Charging System	56-60
Starting Circuit	60-63
Control Circuits	63-65
SECTION 4 - HYDRAULIC SYSTEM (For pressures, see page 10)	
Introduction	66, 67
System Maintenance	68, 69
Main Hydraulic System	69-79
Track Drive Circuit	80-87
Swing Circuit	88, 89
Hoist Cylinder Circuit	90, 91
Crowd Cylinder Circuit	92, 93
Tool Cylinder Circuit	93, 94
Leveler Cylinders Circuit	94, 95
Hydraulic Circuit for Feller-Buncher (shear)	96-99
Rotary Cutter Circuits	100-107
SECTION 5 - TROUBLESHOOTING	
Introduction	109, 110
Mechanical Components	111-114
Electrical System	114-117
Hydraulic System and Components	117-124
SECTION 6 - DISASSEMBLY AND REPAIR	
General Cleaning Instructions	125
Mechanical Components	126-194
Hydraulic Components	195-257
TORQUE CHARTS AND SCHEMATICS	
Torque Charts	258, 259
Electrical Schematics	261, 262
Hydraulic Schematics	263-265
SUPPLEMENT 1 - INSTRUCTIONS FOR SETTING UP AND SHARPENING ROTARY CUTTER BLADE	266-283

1

2

3

4

5

6

GENERAL

ALPHABETICAL INDEX

A

Air Cleaner 17, 34
 Alternator 51, 53, 57
 Alternator Belt Adjustment 58
 Attachments 40, 177

B

Battery 18, 58
 Bearing, turntable 19, 36
 Belts, fan 34
 Boom 40, 177
 Brakes
 Swing (house) 36, 161
 Track (parking) 29, 133

C

Cab Insulation 9
 Capacities, Lubricants and Fluids 11
 Cold Start System 63
 Control Linkages 45
 Cooler, oil 33, 71
 Cooling System, engine 32
 Cutter, rotary 23, 42, 184
 Cylinders, hydraulic 11, 241

D

Drive, track 25
 Drive Transmission, final 22, 29, 138, 153

E

Electrical System 46
 Engine 32

F

Feller Buncher Attachment 23, 41, 179
 Filters
 Air 17
 Fuel 16
 Hydraulic 20
 Fuel Tank 18

G

Gauges, replacement of 64
 Grease Fittings 14

H

Heater, cab 65
 Hydraulic Circuits
 Crowd 92
 Feller Buncher Shear 98
 Hoist 90
 Leveler 94
 Main 69
 Rotary Cutter 100
 Swing 88
 Tool 93
 Track Drive 81
 Hydraulic Oil Tank 21, 256
 Hydraulic Swivel, 7-port 85, 238
 Hydraulic System, maintenance 21, 68

I

Inner Swivel 86
 Instruments 64

L

Leveler, turntable 25, 126
 Lights 55, 64

L

Lubricants 10, 11

M

Maintenance Chart 12, 13
 Main Relief, adjustment 79
 Motors, hydraulic
 Rotary Cutter Drive 189
 Swing 227, 231
 Track Drive 215, 223

O

Oil Cooler 33, 71
 Oil Recommendations 10

P

Pillow Blocks 14, 29, 158
 Pressure Settings, hydraulic 10, 107
 Pump Drive Plate 35, 159
 Pumps, hydraulic
 Main 71, 195
 Rotary Cutter 193

R

Radiator 33
 Relief Valves 10, 75, 79
 Rotary Cutter 23, 42, 184

S

Sharpening Instructions
 Rotary Cutter Blade 271
 Shears 41
 Specifications 8
 Swing Brake (House) 36, 167
 Swing Gearbox 19, 36, 163
 Swivel, 7-Port 85, 238

T

Tank, hydraulic oil 21, 256
 Track
 Adjustment 27
 Chain 27, 127
 Final Drive 22, 29, 138, 153
 Idler Wheel 28, 131
 Rollers 25, 129
 Troubleshooting Charts 111-124
 Turntable Bearing
 Alignment of Swing Gearbox 174
 Capscrews, torquing of 19, 37
 Lubrication 19
 Replacement 171

V

Valves
 Directional Control (Rotary Cutter) 101, 254
 Diverter (Rotary Cutter) 101, 253
 Dual Relief (Rotary Cutter) 106, 255
 Leveler Lock 94, 236
 Main Control 72, 210
 Main Relief 79, 214
 Multiple Check (Collector) 98, 256
 Port Relief 75, 213
 Swing Cushion 89, 236
 Voltage Regulator (Case Engine) 5.

W

Wiring Harness, replacement 65

SAFETY



THIS SAFETY ALERT SYMBOL INDICATES IMPORTANT SAFETY MESSAGES IN THIS MANUAL. WHEN YOU SEE THIS SYMBOL, CAREFULLY READ THE MESSAGE THAT FOLLOWS AND BE ALERT TO THE POSSIBILITY OF PERSONAL INJURY OR DEATH.



CAUTION: When doing any service on the machine, put a tag on the key switch or remove the key to prevent operation of the machine.



WARNING: Never disconnect any hydraulic line unless the boom is fully lowered and hydraulic pressure is released. To release hydraulic pressure, stop the engine and move the hydraulic controls forward and back several times.



WARNING: To prevent injury and possible death, keep hands, feet and loose clothing away from moving parts during operation.



DANGER: Engine exhaust can cause death. If necessary to start the engine in a closed area, make sure there is enough ventilation.



WARNING: To prevent injury from burns, always use a solvent that is not flammable for cleaning component parts. **DO NOT** use gasoline or other flammable substances.



WARNING: Never fill the fuel tank near an open flame or while the engine is running. Keep cigarettes away.



CAUTION: When checking coolant, remove radiator cap slowly to relieve pressure in the system. To prevent burns, remove radiator cap only when engine is cool.



WARNING: To help prevent eye injury, wear eye protection when servicing this machine.



When bleeding brakes, loosen bleeder plug approximately one-half to three-quarter turn or until oil just starts to flow. If plug is loosened too far, it may be blown out under pressure.



CAUTION: Use brake fluid to clean rubber parts. Acetone, paint thinner or other mineral base solvents must not be used on rubber parts. Mineral base solvents will cause damage and possible failure of the part.



WARNING: Stop the engine before doing any maintenance or adjustments. If necessary to make checks while the engine is running, have one person at the controls while the other person makes the check.



Keep a fire extinguisher available and **KNOW HOW TO USE IT.** Check the fire extinguisher at regular intervals for correct operation.



WARNING: Batteries produce explosive gases. Keep sparks, flame and cigarettes away. Ventilate when charging or using in enclosed space. Always shield eyes when working near batteries.



POISON/DANGER: Batteries contain sulfuric acid which can cause severe burns. Avoid contact with skin, eyes or clothing. Antidote: **EXTERNAL,** flush with water; **INTERNAL,** drink large quantities of water or milk. Follow with milk of magnesia, beaten egg or vegetable oil. Call physician immediately. **EYE,** flush with water for 15 minutes and get prompt medical attention. Keep out of reach of children.



WARNING: Never check battery charge by placing a metal object across the posts — the sparks could cause an explosion. Use a voltmeter or hydrometer



DO NOT wear loose clothing which may catch in moving parts.

GENERAL



CAUTION: ENGINE FAN AND BELTS. To prevent possible serious injury avoid contact with rotating fan and belts.



CAUTION: Never operate the alternator on an open circuit. With no battery or other electrical load on the circuit, high voltage will occur in the alternator. This voltage can cause injury to any person who makes contact with the battery terminal of the alternator.



CAUTION: When removing a battery, always disconnect the (-) negative ground cable first. When installing the battery, always connect the (-) negative ground cable last.



CAUTION: Storage areas for batteries must be well ventilated to prevent accumulation of hydrogen gas from newly recharged batteries.



Disconnect both cables from the battery before you work on the engine or electrical system. Always disconnect the (-) negative ground cable first.



CAUTION: Hydraulic systems are highly pressurized. Escaping hydraulic oil, even an invisible pinhole leak, can penetrate body tissues causing serious injury. Use a piece of wood or cardboard when looking for leaks — never use the hands or other parts of the body.

Relieve hydraulic pressure before disconnecting circuits. When reassembling, make absolutely certain that all connections are tight.

If injured by hydraulic oil escaping under pressure, see a doctor immediately. Serious complications may arise if medical attention is not given at once.



CAUTION: When checking coolant level, remove cap on radiator slowly to relieve pressure within the system.



WARNING: Read the Operator's Manual before operating the machine.



CAUTION: Clean any oil spills immediately and keep the work area as clean as possible. A clean area helps prevent accidents.



WARNING: To avoid personal injury, keep hands clear of turntable ring gear while turntable is being rotated.



Never smoke while refueling, servicing the fuel system or working with batteries.



CAUTION: When releasing grease from track adjustment cylinder, loosen adapter only enough to let grease escape. Do NOT loosen the grease fitting on the adapter. Very high pressure exists in the cylinder when under tension. The adapter and/or grease fitting could fly loose and cause personal injury.



CAUTION: The idler wheel spring is under tension. If for any reason this spring must be removed, use EXTREME caution.



Inspect the machine daily for loose, worn or damaged parts. Have unsafe conditions corrected immediately.



CAUTION: Before removing or disassembling the swing brake, SET BOOM TO GROUND to prevent turntable from rotating.



WARNING: If boom is removed, do not swing the turntable over the side of the crawler base. The machine will tip. Never remove the boom unless the upperstructure is directly over the front or rear of the crawler base.



CAUTION: Activate the horn or give a warning to all persons in the area before you start the engine or move the machine.



CAUTION: Wear safety goggles and leather gloves when sharpening rotary cutter blades. Keep eyeshield in place when using grinder. Read and understand sharpening instructions before using this device. Failure to follow these instructions could result in serious injury.

GENERAL INFORMATION

INTRODUCTION

This manual gives information on maintenance and service of the DROTT 40BLC FELLER-BUNCHER. All components, systems and functions are included, except the engine. Information on maintenance and service of the engine is in a separate manual.

There are two main parts in this manual. The first part gives information on maintenance, description and troubleshooting. The second part gives instructions for disassembly and repair of components.

Preventive Maintenance is in a separate section at the front of the book and can be used as a ready reference for normal maintenance of the machine. The section includes a Maintenance Chart, recommendations for lubricants, fuels and fluids, capacities, hydraulic pressures and a list of grease fittings.

For purposes of explanation, the machine is separated into three general systems: Mechanical, Electrical and Hydraulic.

Troubleshooting charts for all the systems are in a separate section (See Section 5).

Torque Charts and Schematic Drawings of the Electrical and Hydraulic systems are included in back of this manual for easy reference when troubleshooting the machine.

If further service information is needed, call your nearest DROTT dealer or Service Representative for assistance.

EXPLANATION OF INTERNATIONAL SYMBOLS

Symbols are a universal language. The symbols shown here are found in the maintenance chart.



 GEAR BOX	 HYDRAULIC RESERVOIR	 HYDRAULIC FILTER	 FILTER AIR
 COOLANT	 ENGINE OIL	 DIESEL FUEL	 LUBRICATE WITH Multipurpose Grease

PARTS AND SERVICE

When you write to the dealer or manufacturer about your DROTT machine, always give reference to the model and PIN (Product Identification Number) of the machine, in addition to the name and location of the part or component. The PIN plate is on the lower right corner of the cab (Figure 1).

All main components of the machine have an identification plate or number on the component housing. The location of the engine serial number plate is shown in Figure 2.

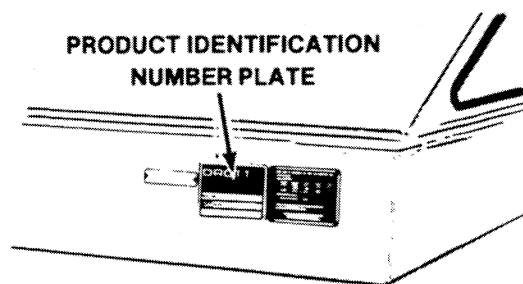

Figure 1. Machine Identification

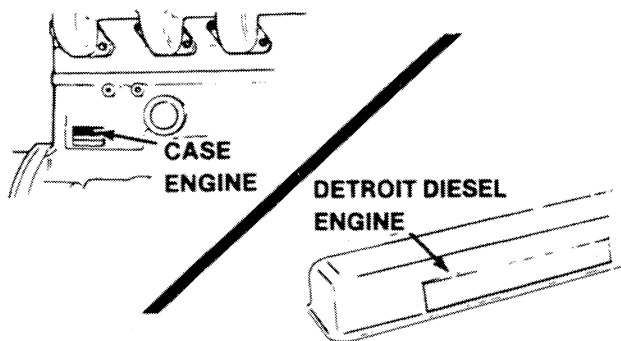

Figure 2. Engine Serial Plate

NOMENCLATURE

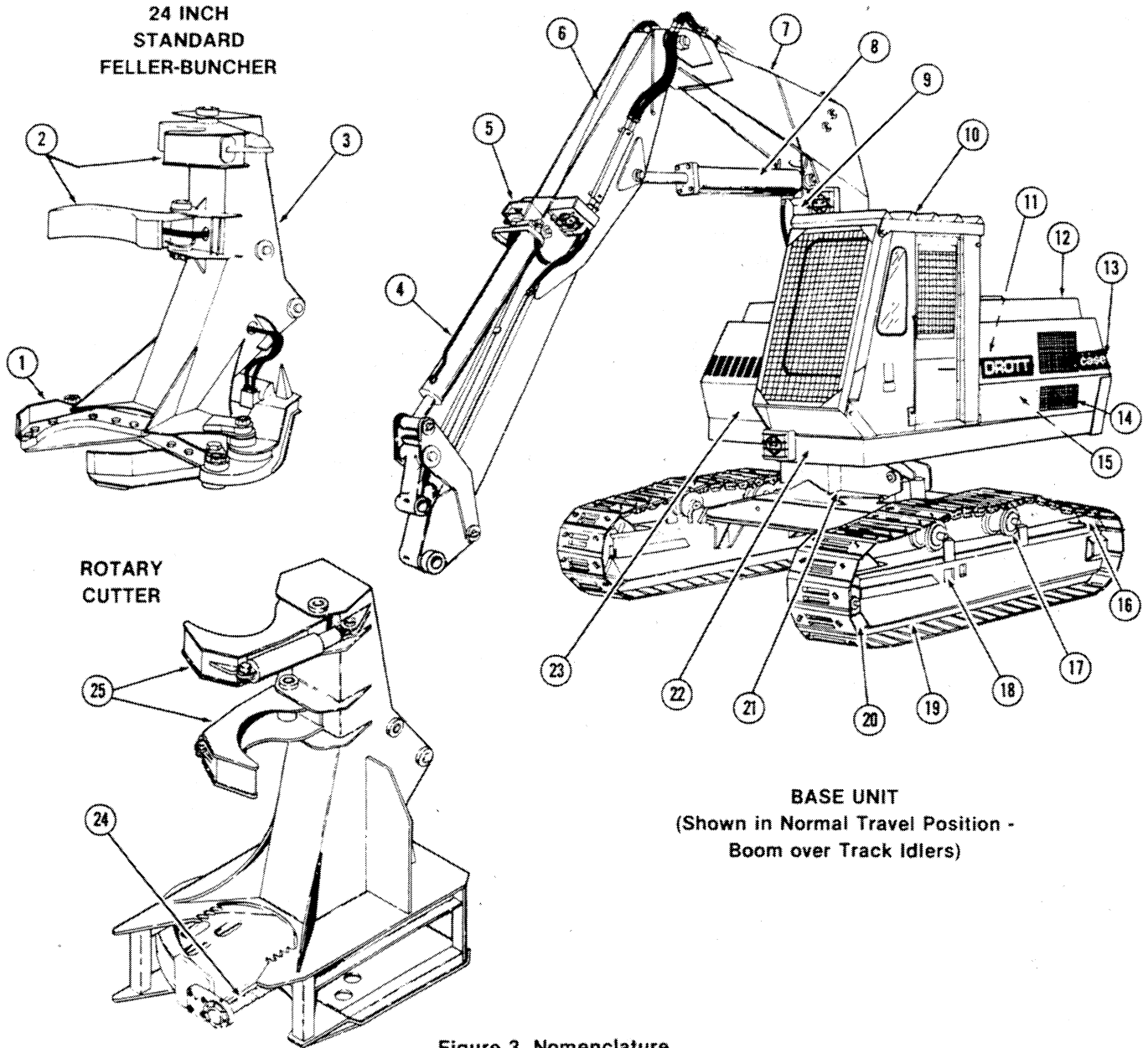

Figure 3. Nomenclature

- | | | |
|--------------------------|--|---|
| 1. Shear Arm | 10. Logger Cab | 18. Location of Track Adjuster |
| 2. Grab Arms | 11. Location of Main Control Valves | 19. Location of Track Rollers |
| 3. Feller-Buncher Head | 12. Engine Compartment | 20. Idler Wheel |
| 4. Tool Cylinder | 13. Location of Counterweight | 21. Turntable Leveler (Optional) |
| 5. Work Light (Optional) | 14. Location of Pump | 22. Turntable Bearing |
| 6. Tool Boom | 15. Location of Hydraulic Oil Tank | 23. Location of Fuel Tank and Swing Mechanism |
| 7. Main Boom | 16. Drive Sprocket and Location of Final Drive | 24. Rotary Cutter Blade |
| 8. Crowd Cylinder | 17. Carrier Roller | 25. Grab Arms |

MACHINE DIRECTIONS

The turntable on the 40BLC rotates a full 360 degrees. The normal travel position is with the boom over the front of the undercarriage (idler end) as shown in figure 4. In this position, directions for both the turntable and the undercarriage are the same. All machine references in this manual to Front, Rear, Right and Left are made in reference to this position. RIGHT is the Operator's right; LEFT is the Operator's left.

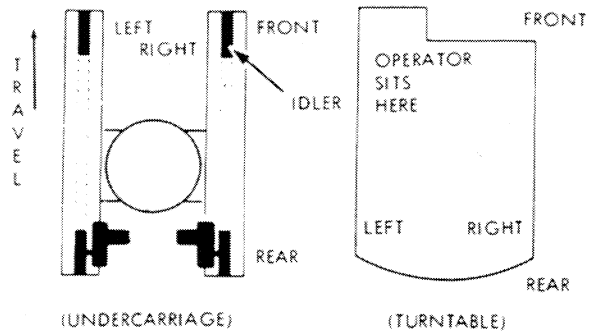

Figure 4. Machine Direction

GENERAL DESCRIPTION

The Drott 40BLC is a fully hydraulic Unit. Power from the engine becomes hydraulic energy, then is changed to mechanical force by the hydraulic cylinders and motors.

two sections is sent through the main control valves to the machine functions. Mechanical linkages connect the valve spools to the operator's cab.

In the hydraulic system, oil from a gear pump with

Figure 5 shows the flow of power from the engine to the machine functions.

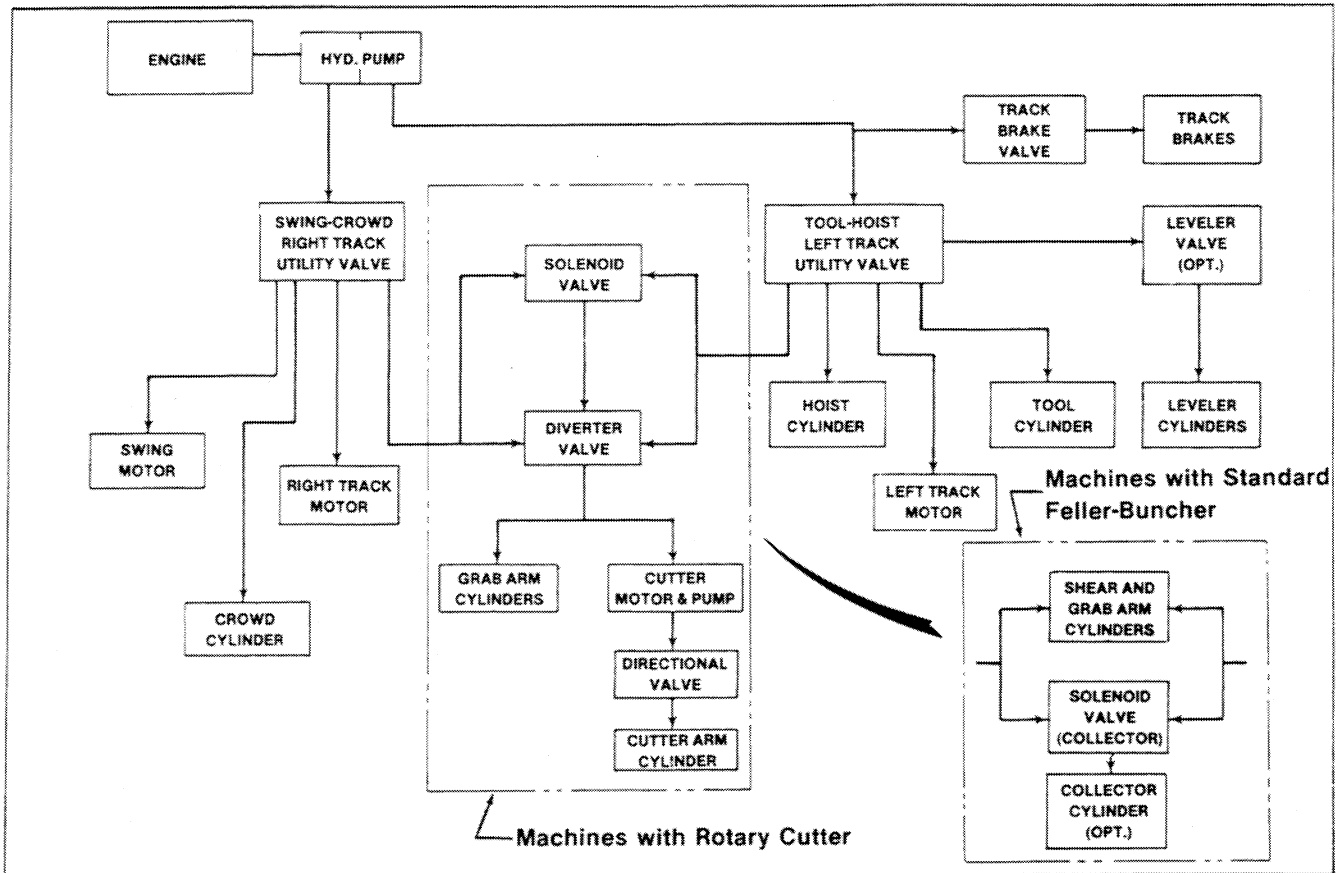

Figure 5. Basic Diagram - 40BLC Feller-Buncher

SECTION 1 PREVENTIVE MAINTENANCE

INTRODUCTION

Preventive maintenance at regular intervals is necessary to keep the machine in good condition as long as possible. Adjust the maintenance schedule to your operation, according to the type of work, size of loads, temperature conditions and frequency of equipment use.

The intervals in the Maintenance Chart are for average operating conditions, and must be understood as the **MINIMUM** maintenance necessary for the machine. More frequent maintenance is necessary if the machine is operated in conditions that are below average (for example, in dust, in high or low temperatures, with heavy loads or frequent starting and stopping).

Use the hourmeter, a calendar and a check list to make sure that all necessary maintenance is done according to the schedule.

CAB INSULATION

Be careful when you clean the cabs which have sound reduction insulation. To clean the insulation, use only a vacuum cleaner or cloth with a small amount of water or mild detergent solution.

DO NOT wash, clean with steam or use a water hose on the insulation. The sound reduction ability of the insulation will be decreased or destroyed if the insulation gets wet.

SPARK ARRESTING MUFFLERS

NOTE:

Laws of some states or provinces may require that this unit be equipped with a SPARK ARRESTOR OR SPARK ARRESTING MUFFLER. The State of California as an example, is one state which has such regulations for agricultural and forestry application, plus a regulation for construction applications in forest-covered, brush-covered, or grass-covered lands.

Typically, such laws and regulations require spark arresting devices to be maintained in good working order and typically to be attached to the exhaust system on naturally aspirated engines (engines without turbo charger).

LUBRICANTS

It is not Drott policy to publish lists of approved lubricants or to guarantee lubricant performance. The responsibility for the quality of any lubricant rests completely with the distributor or manufacturer of the lubricant.

In various paragraphs of this manual, you will find the statement "Use (lubricant brand name) or equivalent." This statement does not constitute an unconditional guarantee of the performance of the brand of oil mentioned; it is intended only as a guide to the type of lubricant recommended for a given application.

IMPORTANT

Always install new decals whenever the old decals are destroyed, lost, painted over, or illegible. When individual parts are replaced that have decals attached, be sure to install a new decal with the new part. Replacement decals are available from your Drott dealer.

PREVENTIVE MAINTENANCE

HYDRAULIC OIL RECOMMENDATIONS

Drott DHF Fluid is the hydraulic oil recommendation for use in the hydraulic system. Other oils selected must compare with the following specifications.

OIL WEIGHT	SYSTEM OPERATING TEMPERATURE
SAE 20-20W	50° to 210° F (10° to 99° C)
SAE 10W	0° to 180° F (- 18° to 82° C)
SAE 5W or 5W-20	Arctic Conditions

Viscosity: The viscosity of the oil must not be more than 4000 SSU (Universal Saybolt Seconds) when the engine is started, or go below 60 SSU for long periods of operation at high temperatures. Normal operating conditions are between 80 SSU and 180 SSU. The viscosity range must not be less than 90 (for this application).

Very Cold Temperature Conditions: SAE 5W or SAE 5W-20 oils can be used if the viscosity of the oil will not be less than 60 SSU at maximum operation temperature. It is necessary to use a preheater and a longer than normal warming period at low operation speed to heat the oil to operating temperature.

HYDRAULIC SYSTEM OPERATING PRESSURES

VALVE/CIRCUIT	LOCATION	PRESSURE SETTING	
		psi	kPa
Main Relief No. 1	Inlet to Crowd Valve	2500	17 237
Main Relief No. 2	Inlet to Hoist Valve	2500	17 237
Main Relief No. 3	Inlet to Leveler Valve	2050	14 130
Swing Port Reliefs	Cylinder ports of inside (crowd) valve	2500	17 237
Crowd Port Relief - Front		2500	17 237
Crowd Port Relief - Rear		3000	20 685
Track Right Port Reliefs		2500	17 237
Utility No. 1 Port Relief - Front		3000	20 685
Utility No. 1 Port Relief - Rear		2500	17 237
Tool Port Reliefs	Cylinder ports of outside (Hoist) valve	3000	20 685
Hoist Port Reliefs		2500	17 237
Track Left Port Reliefs		2500	17 237
Utility No. 2 Port Relief - Front		3000	20 685
Utility No. 2 Port Relief - Rear		2500	17 237
Swing Cushion Valve	In-line	1350	9 300
Collector Relief	In-line	2500	17 237

NOTE: For Hydraulic pressure settings for rotary cutter, see page 107.

COMPONENT CAPACITIES

Component	Capacity	Lubricant/Fluid
Engine Crankcase: Detroit Diesel 4-71N w/filter change	14 qt (13.2 L) 16 qt (15.1 L)	See recommendations of engine manufacturer in engine manual
Case 504BD w/filter change	12 qt (11.3 L) 13 qt (12.3 L)	
Engine Cooling System	8½ gal (32 L)	½ ethylene glycol base anti-freeze, ½ water
Fuel Tank	75 gal (284 L)	No. 2 Diesel Fuel (See engine manual)
Hydraulic Oil Tank	18.7 gal (70 L)	Drott DHF Fluid or equivalent, see page 10.
Complete Hyd. System	53 gal (200 L)	
Final Drive Transmission	Machines through PIN 882 4.5 qt (4.2 L) Machines with PIN 883 and After 14 qt (13.2 L)	E.P. 80-90 gearlube
Swing Gearbox	11 pt (5.2 L)	E.P. 80-90 gearlube
Ring Gear of Turntable Bearing	Use enough to get good lubrication	Open gear lube (spray type) example: Mobilnac E, Texaco Crater Compound or equivalent
Pressure Gun Grease Fitting	Use enough to remove old grease and contamination	Multipurpose E.P. No. 2 lithium grease, molydisulfide grease or equivalent.

HYDRAULIC CYLINDERS (Bore X Stroke)

CYLINDER	Units with 16 inch (406 mm) Shear		Units with 20 inch (508 mm) Shear		Units with 24 inch (610 mm) Shear		Rotary Cutter	
	Bore	Stroke	Bore	Stroke	Bore	Stroke	Bore	Stroke
Hoist, Crowd	6.53 in. (165 mm)	45.50 in. (1155 mm)	6.53 in. (165 mm)	45.50 in. (1155 mm)	6.53 in. (165 mm)	45.50 in. (1155 mm)	6.53 in. (165 mm)	45.50 in. (1155 mm)
Tool	5.50 in. (139 mm)	45.50 in. (1155 mm)	5.50 in. (139 mm)	45.50 in. (1155 mm)	6.53 in. (165 mm)	45.50 in. (1155 mm)	6.53 in. (165 mm)	45.50 in. (1155 mm)
Grab Arms	3.50 in. (89 mm)	9.70 in. (246 mm)	4.75 in. (120 mm)	10.00 in. (254 mm)	4.75 in. (120 mm)	10.00 in. (254 mm)	4.75 in. (120 mm)	10.00 in. (254 mm)
Cutter/ Shear Arm	6.25 in. (158 mm)	15.00 in. (380 mm)	6.50 in. (165 mm)	24.50 in. (622 mm)	8.00 in. (203 mm)	29.50 in. (750 mm)	4.75 in. (120 mm)	10.00 in. (254 mm)
Collector	Does Not Apply		3.50 in. (89 mm)	9.70 in. (246 mm)	3.50 in. (89 mm)	9.70 in. (246 mm)	3.50 in. (89 mm)	9.70 in. (246 mm)

MAINTENANCE CHART

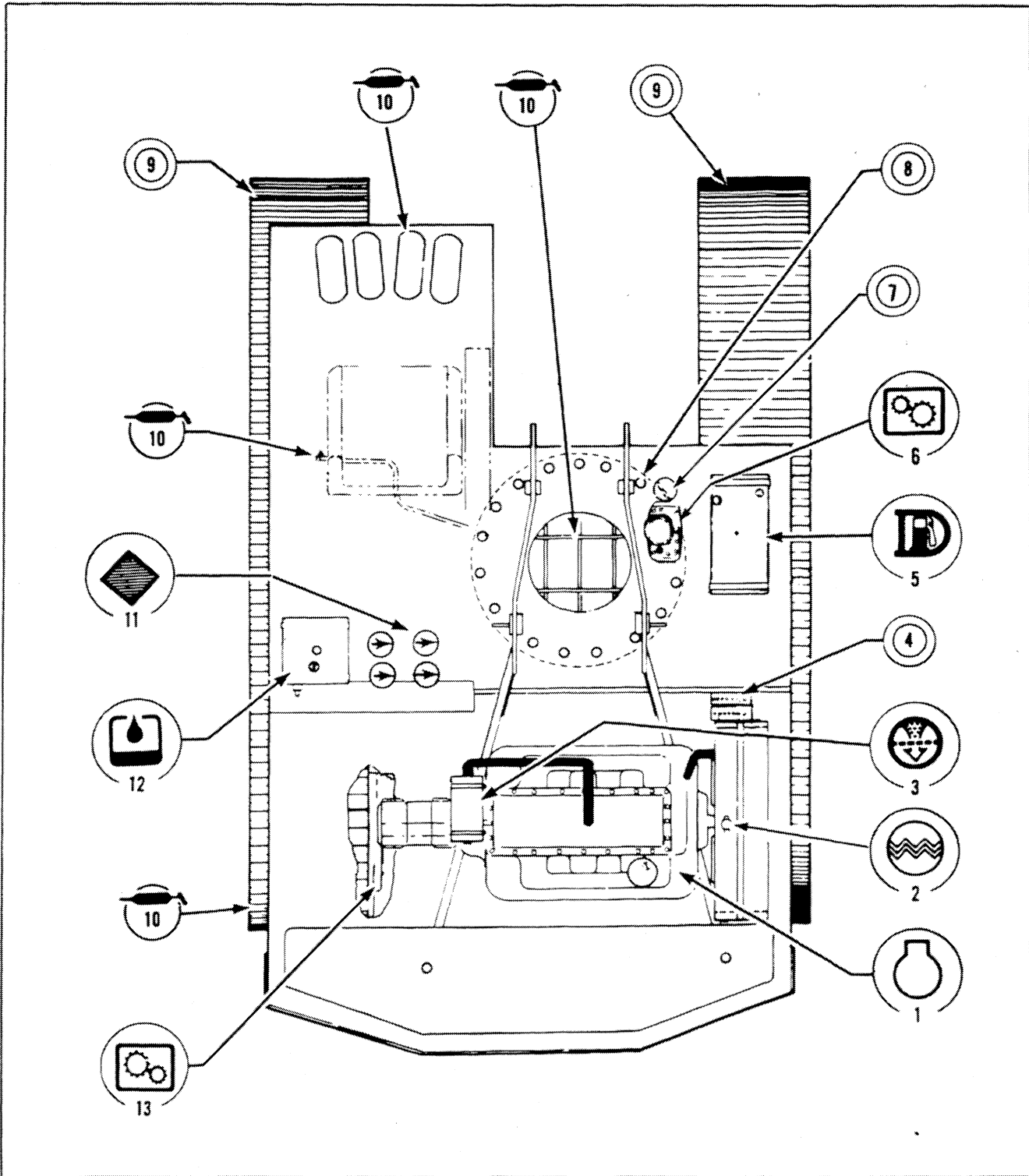

Figure 6. Maintenance Chart

Daily - 10 Hours
 Weekly - 50 Hours
 2 Weeks - 100 Hours
 Monthly - 250 Hours
 2 Months - 500 Hours
 6 Months - 1500 Hours
 12 Months - 3000 Hours

PREVENTIVE MAINTENANCE CHART

REF.	COMPONENT/SYSTEM	Daily - 10 Hours	Weekly - 50 Hours	2 Weeks - 100 Hours	Monthly - 250 Hours	2 Months - 500 Hours	6 Months - 1500 Hours	12 Months - 3000 Hours	SERVICE/CHECK	INSTRUCTION	
1	ENGINE	X							Check oil, drain fuel filter	See Engine Manual	
				X					Change oil and filters	See Engine Manual	
2	RADIATOR, COOLING SYSTEM	X							Check coolant level	See page 16	
			X						Clean fins, remove obstruction, check fan belts	See page 32	
					X					Check specific gravity, add corrosion inhibitor	See page 33
							X			Drain and flush system	See Engine Manual
3	AIR CLEANER	X							Check restriction indicator, empty dust cup	See page 17	
					X				Clean or replace element	See page 17	
4	BATTERIES		X						Check electrolyte level (except "Maintenance Free" type)	See page 17	
							X		Clean battery case, posts and connections	See page 17	
5	FUEL TANK	X							Fill at end of shift, drain water from tank	See page 17	
					X				Clean breather	See page 17	
6	SWING GEARBOX		X						Check oil level	See page 19	
							X		Change oil, clean breather	See page 19	
7	TURNTABLE BEARING	X							Lubricate the ring gear	See page 19	
			X						Lubricate the bearing race (thru Central Lube)	See Illustrated Listing	
8	TURNTABLE CAPSCREWS				X			Check torque (See also "Special Maintenance" below)	See page 37		
9	TRACK	X							Grease pillow blocks, clean tracks	See Illustrated Listing	
			X						Check and adjust track tension	See page 27	
10	LUBRICATION FITTINGS	X	X					Apply grease per intervals in Illustrated Listing	See page 14		
11	HYDRAULIC FILTERS				X			Clean 100 mesh screen, replace paper element	See page 20		
12	HYDRAULIC OIL TANK	X							Check oil level	See page 21	
					X				Replace breather	See page 22	
						X			Change oil, clean screens	See page 21	
13	FINAL DRIVE TRANS.		X						Check oil level, look for damage or leaks	See page 22	
							X		Change oil	See page 22	
14	CAB and CONTROLS	X							Clean cab, check operation of controls	See page 9	
					X				Check condition and adjustment of the controls	See page 45	
15	BOOM and ATTACHMENT	X						Lubricate thoroughly	See page 40		

SPECIAL MAINTENANCE

End of First Day or First 10 Hours of Operation

Hydraulic Filters Replace paper element, clean 100 mesh screens
 Hose clamps Tighten all hose clamps on air intake system, radiator hoses and hydraulic hoses

After First 20 Hours of Operation

Case engine Change run-in oil and filters. See Engine Manual

After First Week or 50 Hours of Operation

Turntable Capscrews Check for correct torque

LUBRICATION FITTING CHART

Fig. No.	Location/Title	Qty.	Interval
6A	Turntable Bearing	1	Weekly/50 hours
6B	Control Pedals and Levers	8	Weekly/50 hours
6C	Control Linkage under Cab	10	Weekly/50 hours
6D, 6E	Turntable Leveler	4	Weekly/50 hours
6F	Drive Sprocket Pillow Block	2 per side	Daily/10 hours
6G	Boom and Cylinders	11	Weekly/50 hours
6H	Feller/Buncher (shear)	12	Daily/10 hours
	Collector (Optional)	3	Daily/10 hours
6I	Rotary Cutter	13	Daily/10 hours

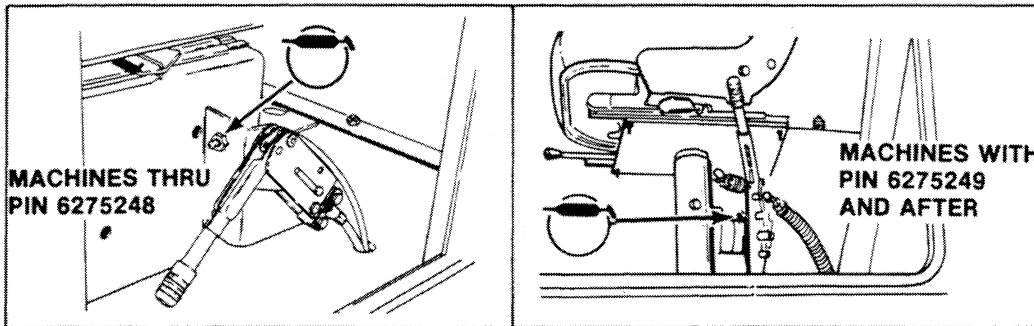

Figure 6A. Lubrication Point for Turntable Bearing (Race)

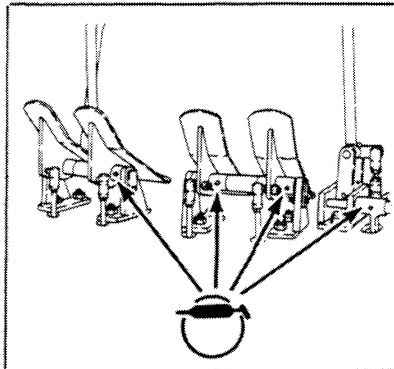

Figure 6B. Grease Fittings on Controls

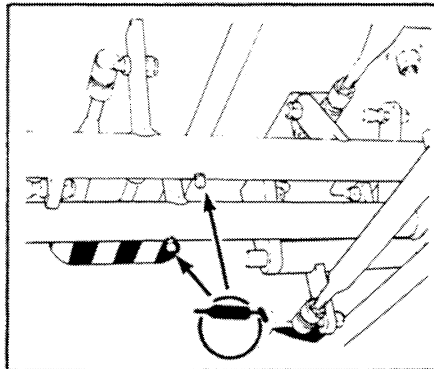

Figure 6C. Grease Fittings on Linkages

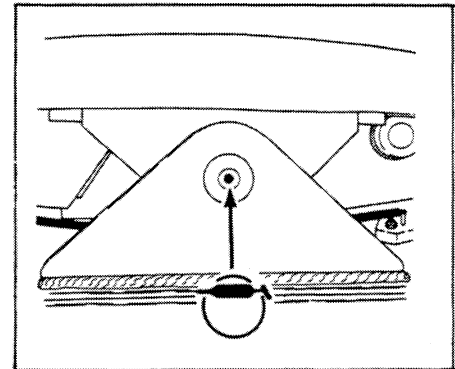

Figure 6D. Grease Fittings on Leveler Pivot

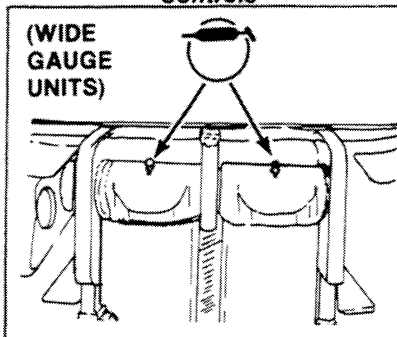

Figure 6E. Grease Fittings on Leveler Cylinders

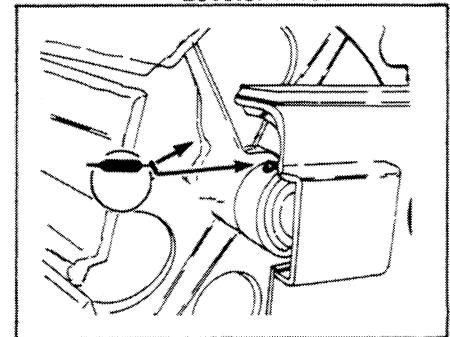
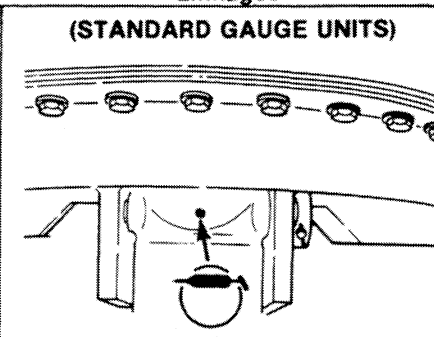

Figure 6F. Grease Fittings on Pillow Blocks

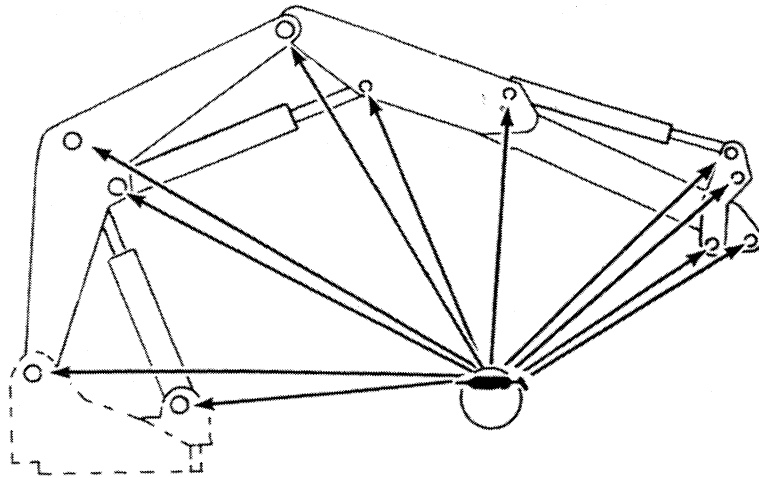

Figure 6G. Grease Fittings on Boom

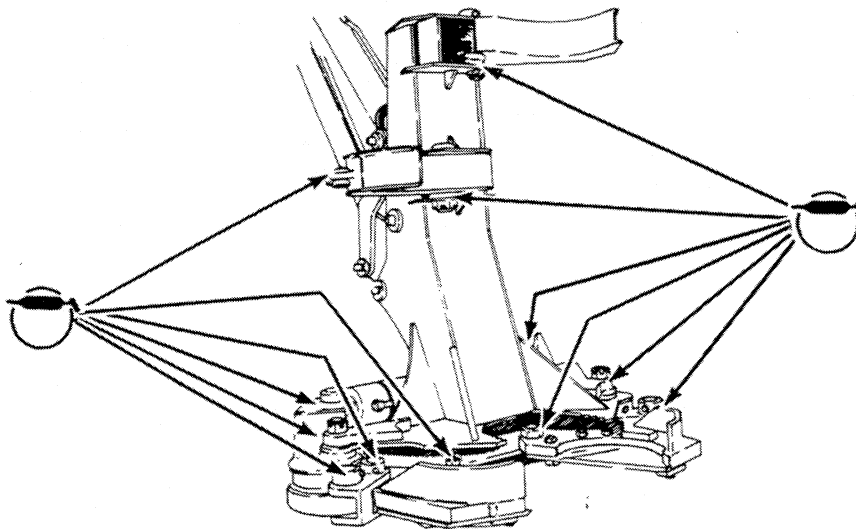

Figure 6H. Grease Fittings on Feller Buncher Shear

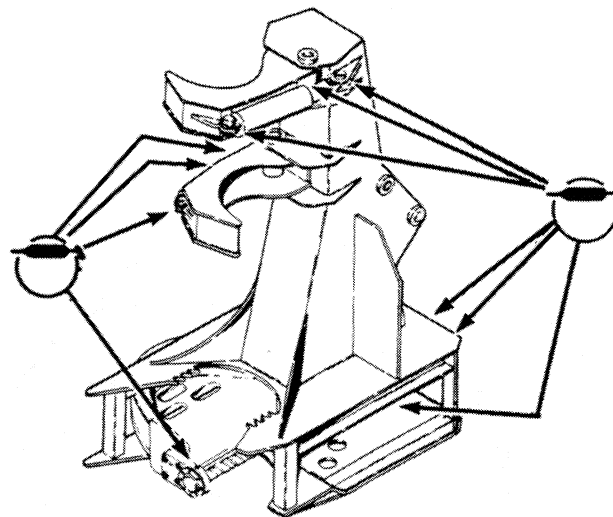

Figure 6I. Grease Fittings on Rotary Cutter

DETAILS OF PREVENTIVE MAINTENANCE

The remaining pages of this section give the details needed to do the preventive maintenance on this equipment. The instructions are put in order of the Maintenance Chart for easy reference.

NOTE: When you do the preventive maintenance, tighten nuts, bolts and clamps where necessary.

1 ENGINE

Read the engine manual and do the necessary maintenance for the engine at the intervals given in the engine manual. Carefully follow the procedure given for run-in of the engine. The following maintenance is especially called to your attention.

Drain Fuel Filters - Daily

Before operation each day, open the drain valve (Detroit Diesel engine) or loosen the drain plug (Case engine) on the bottom of the primary fuel filter. Wait until any water has been released, then tighten the drain valve or plug.

Water or moisture in the fuel will cause damage to the precision components of the fuel injection system. It is important that the fuel is free of water and foreign material. Also see Fuel Tank, item 5.

Check Oil Level - Daily

Before operation each day, make sure the oil is at the correct level (full mark) on the engine dipstick. Add oil as necessary according to the recommendations in the engine manual.

2 COOLING SYSTEM

See Mechanical System section for description of the cooling system used on this machine. See engine manual for description of the water pump, internal passages and circulation system.

Check Coolant Level - Daily

While the engine is still cold, remove the pressure cap on the radiator and check the coolant level. The coolant must be approximately 2 inches (50 mm) below the filler tube. Add coolant as necessary, but do not over-fill. For coolant recommendations, see page 11.

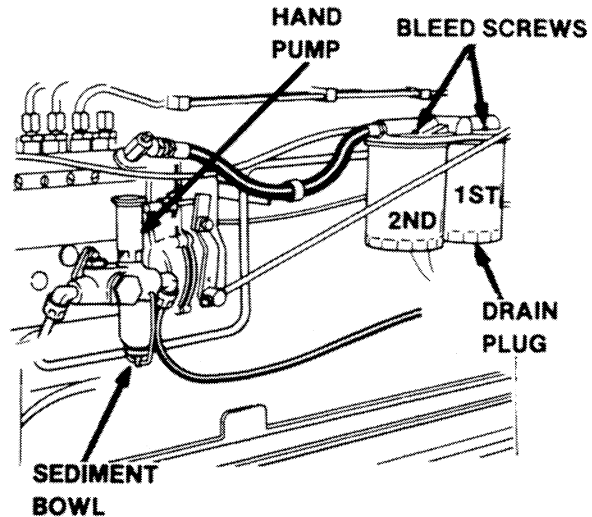

Figure 7. Case Engine

DRAIN PETCOCK

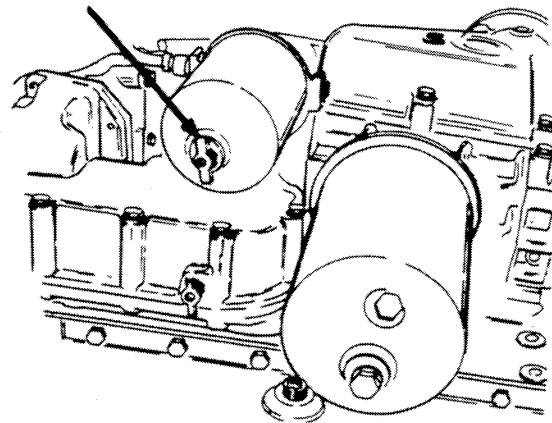

Figure 8. Detroit Diesel Engine



CAUTION: When checking coolant level, remove cap on radiator slowly to relieve pressure within the system.

Other Maintenance:

See Mechanical System section, page 32.

3 AIR CLEANER

Check the restriction indicator on the air intake line daily. When the red band of the indicator is in full view (engine not running), the element needs service. Tighten hose clamps periodically.

After service of the air cleaner, you must reset the indicator by pushing the reset button.

Dust Cup - Daily

When the machine is operated in dust or sand conditions, remove and clean the dust cup before operation each day.

- 1 - Loosen retaining clamp and remove the dust cup.
- 2 - Remove baffle and turn dust cup over to remove the dust.
- 3 - Use a cloth with a small amount of water to clean the baffle and dust cup.
- 4 - Install baffle in cup and assemble dust cup on air cleaner, making sure arrow on cup is towards the top. Tighten retaining clamp.

Air Cleaner Element

There are three ways to clean the element - with compressed air, by washing or both methods. Washing is best because this method removes foreign material which normally can not be removed with compressed air.

NOTE: Never run the engine when the element or dust cup is removed.

- 1 - Use compressed air under low pressure (30 psi [200 kPa] at the nozzle). Hold the nozzle a short distance away and turn the element slowly to make sure you remove as much dust as possible.
- 2 - Wash the element in a filter element cleaner, for example, Case Filter Element Cleaner (available from a Case dealer). Follow the instructions on the container.

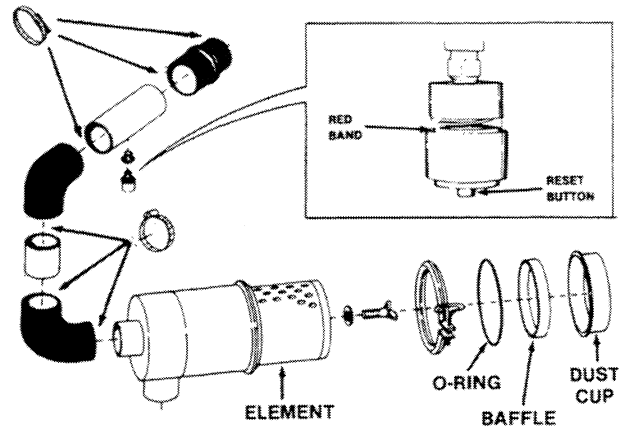

Figure 9. Air Cleaner (Case Engine Installation Shown)

- 3 - After washing, use water under low pressure to remove as much of the solution as possible.
- 4 - Hold an illuminated bulb inside the cleaned element and inspect for damage. Areas which let light through are weak or worn. Also, check for damage to the metal outer cover. If damage or weak areas are found, discard the element.

NOTE: Air cleaner elements must be replaced after 5 cleanings. Keep an extra element in supply for replacement or for use when the other element is being cleaned.

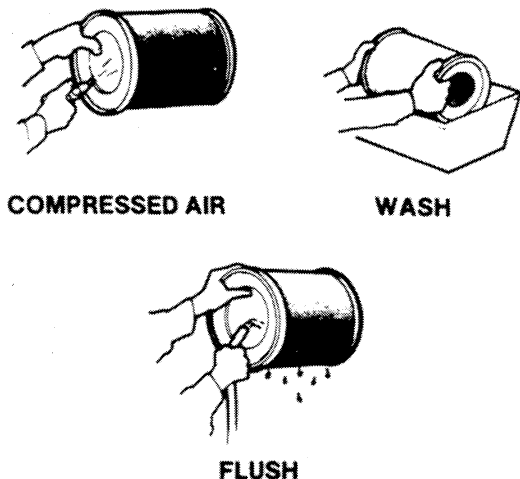

Figure 10. Cleaning of the Element

PREVENTIVE MAINTENANCE

4 BATTERY

Check the electrolyte level weekly or every 50 hours (except "Maintenance Free" type). In hot weather the batteries normally will use more water and must be checked more frequently. Continued high use of water indicates an over-charging condition. See Electrical System section. Add distilled water as needed to keep the electrolyte level above the cell plates.



WARNING: Batteries produce explosive gases. Keep sparks, flame and cigarettes away. Ventilate when charging or using in enclosed space. Always shield eyes when working near batteries.

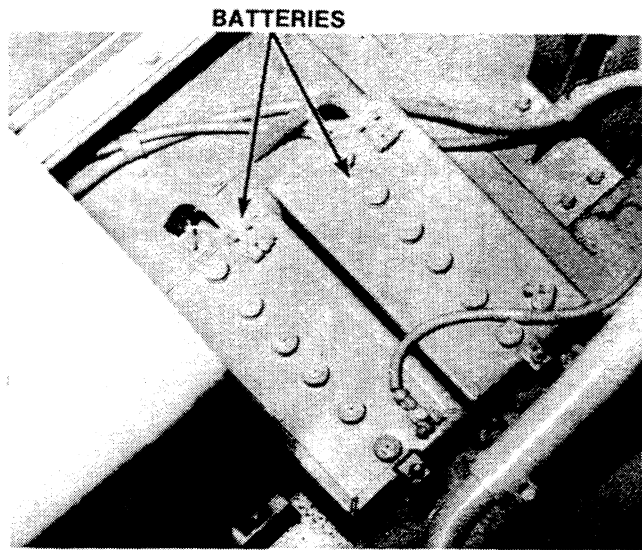

Figure 11. Batteries (Typical Installation)

Cleaning the Batteries

Moisture and dirt on top of the battery case can cause a continuous discharge across the battery. It is important to keep the batteries clean.

Every 6 months, 1500 hours or as necessary, clean the battery terminals, cables and case. Use a soda water solution and flush with clean water. A special brush is available at most automotive centers for cleaning the battery posts and connections. For more information on maintenance of batteries, see page 58.

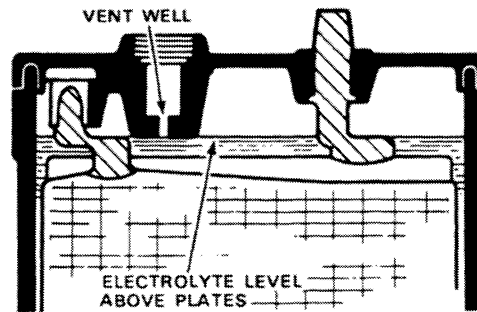

Figure 12. Battery Electrolyte Level

5 FUEL TANK

Condensation in the fuel system can be kept to a minimum if the fuel tank is filled at the end of operation each day. For fuel recommendations, see engine manual.

Drain Water-Trap - Daily

Before operation each day, open the valve on bottom of fuel tank to release the water that has collected in the fuel tank.



WARNING: Never fill the fuel tank near an open flame or while the engine is running. Keep cigarettes away.

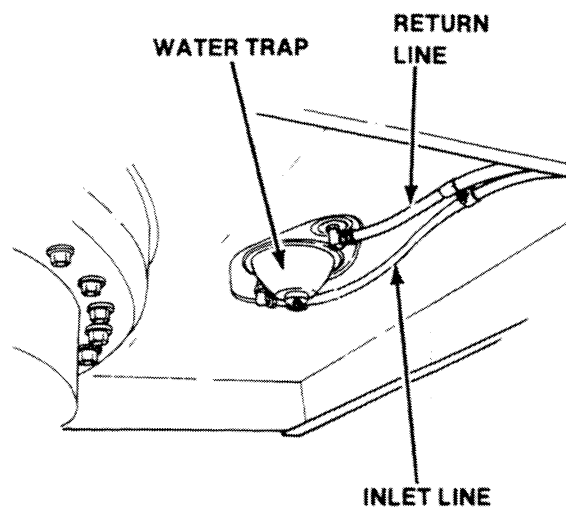

Figure 13. Fuel Tank Water Trap

6 SWING GEARBOX

Check the oil in the gearbox weekly or every 50 hours. To check the oil, remove the breather tube or the pipe plug on top of the cover. (Make sure the turntable is level). Add oil as necessary to keep the gearbox full of oil. For oil recommendation, see page 11.

Oil Change Interval

Change oil in the gearbox every 6 months or 1500 hours, whichever comes first. The drain plug is on the side of the gearbox near the bottom. To remove as much oil as possible, it is necessary to remove the three mounting bolts so you can tilt the gearbox. Use care to keep the shims in the original position under the gearbox.

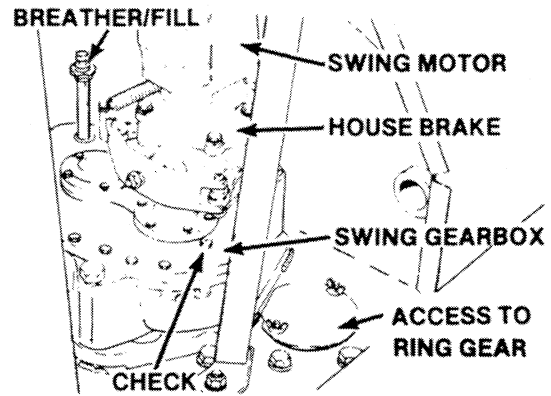

Figure 14. Swing Gearbox

NOTE: Keep the breather clean to prevent high pressure damage to the seals. Use compressed air and a solvent that is not flammable to clean the breather.

7 RING GEAR OF TURNTABLE BEARING

A hole is made in the turntable near the swing gearbox for access to the ring gear of the turntable bearing.

Lubrication Procedure - Daily

Loosen two wing nuts and remove cover from access hole. Use a spray or brush type lubricant, for example, Mobilnac E, Sohio Sohita No. 1, Sunoco 407 Compound B, Texaco Crater Compound or equivalent. Apply the lubricant while the turntable is slowly rotated clockwise through full rotation so the swing pinion moves the lubricant evenly over the teeth of the ring gear.

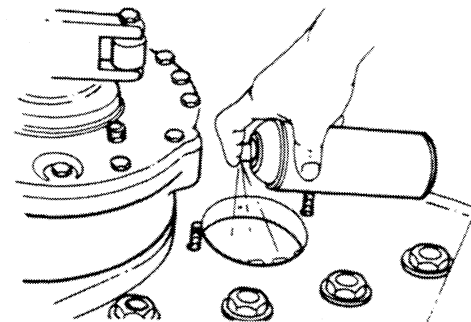

Figure 15. Lubrication of Ring Gear

WARNING: To avoid personal injury, keep hands clear of turntable ring gear while turntable is being rotated.

8 BOLTS FOR TURNTABLE BEARING

A fully rotating machine puts a high stress on the bolts which fasten the turntable bearing to the upper and lower structures. It is important that these bolts be checked at the given intervals.

Tightening Interval

The first check must be made after the first 50 hours or first week of operation, whichever comes first. Check the bolts again after every 250 hours or each month, whichever comes first. For procedure, see page 37.

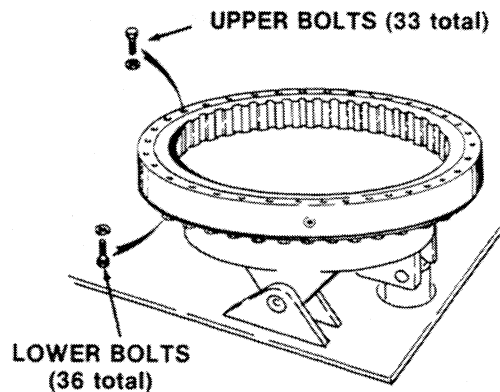

Figure 16. Turntable Bearing Bolts

PREVENTIVE MAINTENANCE

9 TRACK

Accumulation of mud, dirt and stones will cause waste of engine power and increased wear on the track components. Daily cleaning of the tracks will keep the wear to a minimum. See Operator Manual for procedure.

Track Tension

For adjustment of track tension, see page 27.

Track Rollers

The track rollers are sealed and require no periodic lubrication. If leakage is evident, repair or replace the roller. See Section 6.

Pillow Blocks - Daily

Apply grease to the pillow block before operation each day (4 locations). If the machine is working in a wet area, apply grease more frequently. See List of Grease Fittings.

10 GREASE FITTINGS

Apply grease to the pillow blocks before operation. Grease Fittings at the intervals given. Use a cloth to clean the fitting before you apply the grease gun. High wear areas (for example, boom and attachment) need lubrication daily or every 10 hours, whichever comes first. On new machine, apply grease to fittings on boom and attachment after every 4 hours for the first 20 hours of operation.

If any grease fitting does not take grease, remove the fitting and check for obstruction. Grease fittings with damage must be replaced. Always apply enough grease to remove the old grease from the area being lubricated.

11 HYDRAULIC FILTERS (In-Line)

There are two filters in the hydraulic lines at the rear of the boom. See Figure 17.

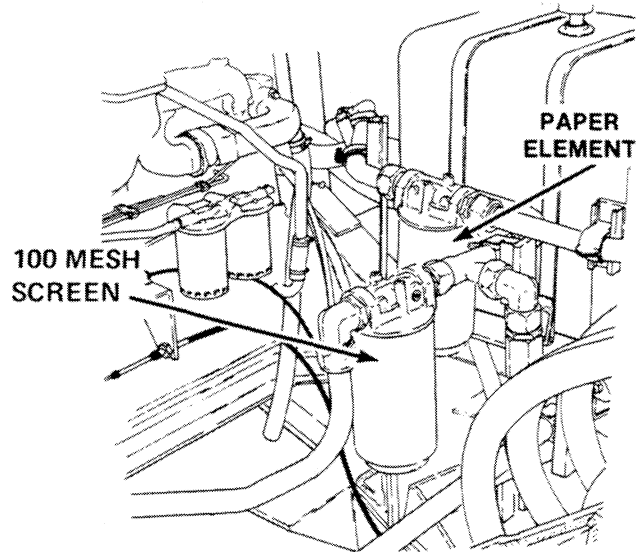

Figure 17. Location of In-Line Filters

First Maintenance:

Clean the 100 mesh strainer and replace the paper element after the first day or 10 hours of operation, whichever comes first. See procedure below.

Normal Maintenance:

After the first maintenance, replace the paper element and clean the 100 mesh strainer after every 2 months or 500 hours of operation, whichever comes first.

NOTE: Use care to keep dirt and foreign material out of the hydraulic system.

1. Apply a vacuum (3 psi max.) to hydraulic oil tank through breather port.
2. Clean the outside of the filters.
3. Loosen and remove the center post, along with the housing, seals and element.
4. Discard the paper element. Clean the 100 mesh strainer in a solvent that is not flammable. Dry with compressed air. If strainer has damage, replace it.

5 - Using new element and seals, assemble the filters:

- a - Put new seal on the center post.
- b - Put housing over the center post and install the conical spring with smaller side down. Install bottom washer, gasket, element, upper gasket and backup washer.

NOTE: Seal gasket, bottom of housing and the flange of the center post must be free of oil or grease to prevent extrusion of gasket when center post is tightened.

- c - Put a new o-ring on the filter head and carefully assemble the filter assembly to the filter head.

NOTE: Make sure the filters are installed in the correct location. The head for the paper filter has a bypass valve. Damage to the element can be caused if the paper element is assembled to the filter head which does not have the bypass valve.

- d - Tighten the center post to a torque of 15 lb-ft (20 Nm).

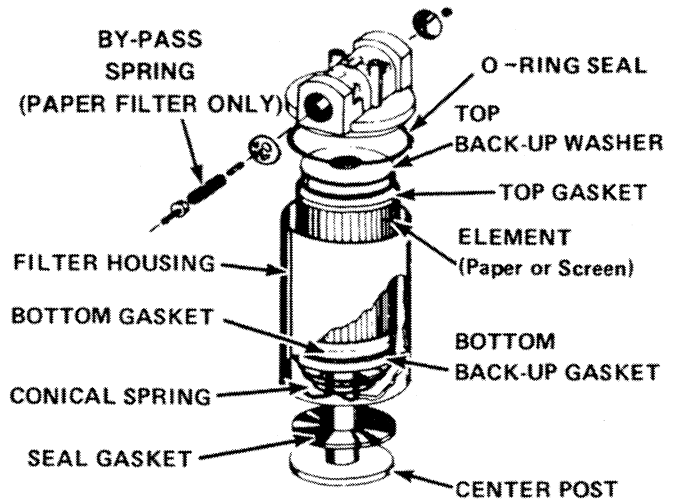

Figure 18. Filter Exploded View

WARNING: To prevent injury from burns, always use a solvent that is not flammable for cleaning component parts. DO NOT use gasoline or other flammable substances.

Oil Change Interval

Every 6 months or 1500 hours, drain the hydraulic oil from the system and add new oil. Use the following procedure.

- 1 - Start engine. Raise main boom, extend stick boom and tilt Feller/Buncher head rearward. Stop engine.
- 2 - Put a container which will hold approximately 55 gallons (208 litres) under the hydraulic oil tank. Remove cap from drain line on bottom of tank. Allow system to drain.

12 HYDRAULIC OIL TANK

Check oil level daily or every 10 hours, whichever comes first. To get a correct indication, the machine must be level and the boom must be in the position shown. Add hydraulic oil as necessary to bring the level to the FULL mark on the dipstick. For hydraulic oil recommendations, see page 10.

NOTE: Clean around the filler cap before removal to keep dirt out of the system.

IMPORTANT: The enemy of any hydraulic system is contamination. Keep all dirt and foreign material out of the system. Use a 200 mesh or finer screen to filter the oil as it is poured into the tank. NEVER use cloth as a filter. The oil will pick up lint as it passes through the cloth.

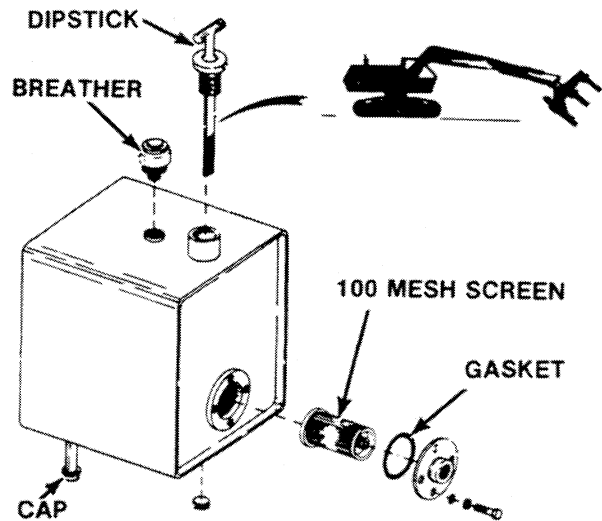

Figure 19. Hydraulic Oil Tank

PREVENTIVE MAINTENANCE

- 3 - As the tank is draining, SLOWLY lower the main boom, retract stick boom, and let Feller/Buncher Head tilt forward. (Do not run the engine.) This procedure will force as much oil as possible from the cylinders.
- 4 - Do the normal maintenance of the two filters in the hydraulic lines. See instruction under item 12
- 5 - Remove and clean the breather for the hydraulic oil tank. Use a solvent that is not flammable. Dry with compressed air. Install breather on tank.
- 6 - When the hydraulic oil tank is empty, remove four bolts from flange on tank outlet. Remove the 100 mesh screen from the flange. Clean the inside of the tank and the screen. Use a solvent that is not flammable. Dry with compressed air. If the screen has damage, replace the screen. Install screen on flange and assemble flange to tank. Use new seal washers on the four mounting bolts for the flange.
- 7 - Install drain cap and fill tank with hydraulic oil of the correct type. See Hydraulic Oil Recommendations. Use a screen (200 mesh or finer) as a filter when you add oil to the tank. The tank filler opening does not have a filter.

REMEMBER: Use care to keep all dirt and foreign material out of the system. NEVER use cloth as a filter because the oil will pick up lint. Make sure the funnel used is clean.

- 8 - After tank has been filled, start the engine and run it at low idle rpm. Slowly operate each function, one at a time to fill the cylinders and hydraulic lines. Continue to add oil as necessary until all cylinders and lines have been filled with oil.
- 9 - Install the filler cap and run the machine through several cycles. Then stop the engine and look for leaks in the filter mountings. Check the oil again to make sure the oil is at the correct level on the dipstick. DO NOT OVER FILL.

Breather for Hydraulic Oil Tank

Clean or replace the breather every 2 months or 500 hours, whichever comes first. It is important that the breather is clean and dry to prevent a vacuum in the hydraulic oil tank. A vacuum will cause cavitation damage to the hydraulic pumps.

Loosen the machine screw and remove cover from breather for access to the element. The element can be cleaned in a solvent that is not flammable. If there is damage, replace the element.

13 FINAL DRIVE TRANSMISSIONS

Check the oil in the transmissions each week or every 50 hours, whichever comes first. Look for signs of leakage (dark areas around seams or openings). Cracks, loose bolts or bad seals will allow moisture and dirt to enter the gear case. The transmissions are in an area where damage can easily be caused by rocks or other obstacles. It is important to check the transmissions frequently.

Oil Change Interval

Drain and refill the final drive transmissions every 6 months or 1500 hours of operation, whichever comes first. Look for particles of metal in the oil which are an indication that the transmission needs overhaul.

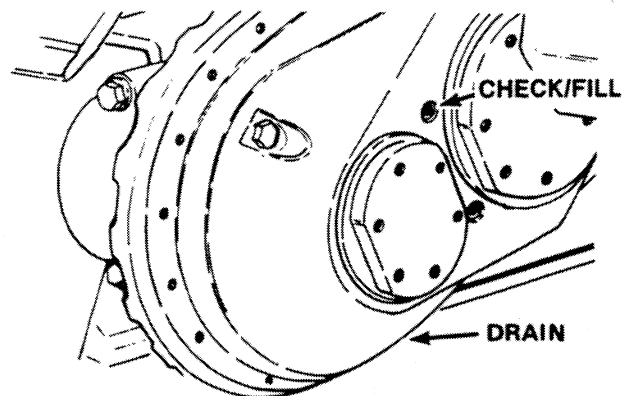

Figure 20. Final Drive Transmission