

584E, 585E and 586E Forklifts
Service Manual

Table of Contents

	Description	Section No.	Form No.
General			
		Tab 1	
	Loctite Product Chart		8-98900
	Safety Rules, Service Manual Introduction and Torque Specifications	1001	8-44810
	Fluids and Lubricants Chart, Systemgard Testing Schedule and Maintenance Chart	1002	8-15550
	General Engine Specifications	1010	8-27400
Engines			
		Tab 2	
	Engine and Radiator Removal and Installation	2000	8-44810
	Air Cleaner, Ether Injection	2001	8-44810
	Stall Tests	2002	8-15680
	Specification Details	2402	8-24163
	Cylinder Head and Valve Train	2415	8-24173
	Cylinder Block, Crankshaft, Pistons, Rods, Camshaft, Main Bearings, Oil Seals and Flywheel	2425	8-24183
	Lubrication System	2445	8-24193
	Cooling System	2455	8-24203
Fuel System			
		Tab 3	
	Engine Controls, Fuel Lines and Fuel Tank	3001	8-15560
	Fuel System and Filters	3410	8-24211
	Fuel Injectors	3413	8-24233
	Fuel Injection Pump and Drive Gear	3414	7-37131
Electrical			
		Tab 4	
	Wiring Diagram	In pocket at rear of manual	
	Removal and Installation of Electrical Components	4001	8-44810
	Specifications and Troubleshooting	4002	8-15570
	Batteries	4003	8-11360
	Instrument Cluster	4004	8-15580
	Starter and Starter Solenoid	4006	8-72280
	Alternator	4019	8-12900
Steering			
		Tab 5	
	Troubleshooting and Pressure Check	5002	8-44810
	Steering Control Valve	5007	8-12930
	Cylinder	5010	9-69280
	Rear Axle - Two Wheel Drive Machines	5021	8-44810
	Rear Axle - Four Wheel Drive Machines (D124605)	5022	8-15590
	Rear Axle - Four Wheel Drive Machines (D134010)	5022	8-15720
Power Train			
		Tab 6	
	Maintenance and Troubleshooting	6202	8-44810
	Removal and Installation of Power Train Components	6209	8-15600
	Power Shuttle	6210	8-44810
	Power Shuttle Controls	6211	8-15610
	Transaxle and Differential Lock	6215	8-15620
	Transfer Gear Box (4-Wheel Drive Machines)	6216	8-23451
	Wheels and Tires	6229	8-15630

Reprinted

Description	Section No.	Form No.
Brakes		
Tab 7		
Brakes (Brake Pedals to Transaxle)	7106	8-44810
Differential Brakes	7123	8-22921
Hydraulics		
Tab 8		
Removal and Installation of Pump Flow Control Valve and Cylinder	8000	8-73680
Maintenance	8001	8-44810
Specifications, Hydraulic Diagram, Troubleshooting and Pressure Checks	8002	8-44810
Cleaning the Hydraulic System	8003	8-44810
Flow Control Valve	8004	8-44810
Pump	8005	8-44810
Control Valve and Control Levers	8007	9-69280
Cylinders	8090	8-15640
Mounted Equipment		
Tab 9		
Masts with Single Lift Cylinder	9040	8-15650
14 Foot (4.3 m) Free Lift Masts	9041	9-69283
21 Foot (6.4 m) Free Lift Masts	9041	8-15661
Masts with Two Lift Cylinders	9042	8-73701
Canopy	9061	9-69280
Seat and Seat Belts	9064	9-69280
Pocket		
Wiring Diagram		860056
Hydraulic Schematic		851508

LOCTITE PRODUCT CHART

Product	Color	Similar Products	Gap (In Inches)	Strength (Steel/Steel)	Working Temperature Range-Fahrenheit	Fixture/Full Cure (Steel/Steel) Time	Primer	Description
#3	Dark Brown					24 hr	N/A	Form a Gasket (works with oil, fuel or grease) Pliable
80	Yellow					Fast	N/A	Weatherstrip Adhesive
123	Clear					N/A	N/A	Parts Cleaner Fluid
220	Blue	290	0.003	57/143 in lbs	-65 to +250	6 min/24 hrs	747	Wicking Threadlocker
221	Purple	222	0.005	75/44 in lbs	-65 to +300	2 min/24 hrs	747	Low Strength Threadlocker
222	Purple		0.005	53/30 in lbs	-65 to +300	20 min/24 hrs	764	Low Strength Threadlocker (Small Screws)
225	Brown	222	0.010	45/25 in lbs	-65 to +300	7 min/24 hrs	747	Low Strength Threadlocker
242	Blue		0.005	80/50 in lbs	-65 to +300	10 min/24 hrs	764	Medium Strength Threadlocker
262	Red	271	0.005	160/190 in lbs	-65 to +300	5 min/24 hrs	747	High Strength Threadlocker
270	Green	271	0.007	160/320 in lbs	-65 to +300	3 min/24 hrs	747	High Strength Threadlocker
271	Red	262	0.007	160/320 in lbs	-65 to +300	10 min/24 hrs	764	High Strength Threadlocker
272	Red	620	0.007	180/220 in lbs	-65 to +450	30 min/24 hrs	764	High Temperature, High Strength
275	Green	277	0.010	210/300 in lbs	-65 to +300	3 min/24 hrs	747	High Strength Threadlocker
277	Red		0.010	225/300 in lbs	-65 to +300	60 min/24 hrs	764	High Strength Threadlocker
290	Green		0.003	85/350 in lbs	-65 to +300	6 min/24 hrs	764	Wicking Threadlocker
*404	Clear	495	0.006	3200 psi	-65 to +180	30 sec/24 hrs	NA	Instant Adhesive
*406	Clear		0.004	3200 psi	-65 to +180	15 sec/24 hrs	N/A	Surface Insensitive Adhesive
*409	Clear	454	0.008	2500 psi	-65 to +180	50 sec/24 hrs	N/A	Gel Instant Adhesive
*414	Clear		0.006	2500 psi	-65 to +180	30 sec/24 hr	N/A	Instant Adhesive
*415	Clear	454	0.010	2500 psi	-65 to +180	50 sec/24 hrs	N/A	Gap Filling Instant Adhesive (Metals)
*416	Clear	454	0.010	2500 psi	-65 to +180	50 sec/24 hrs	N/A	Gap Filling Instant Adhesive (Plastics)
*420	Clear		0.002	2500 psi	-65 to +180	15 sec/24 hrs	N/A	Wicking Instant Adhesive
*422	Clear	454	0.020	2800 psi	-65 to +180	60 sec/24 hrs	N/A	Gap Filling Instant Adhesive
*430	Clear		0.005	2500 psi	-65 to +180	20 sec/24 hrs	N/A	Metal Bonding Adhesive
*445	White/Black		0.250	2000 psi	-65 to +180	5 min/24 hrs	N/A	Fast Setting 2 Part Epoxy
*454	Clear		0.010	3200 psi	-65 to +180	15 sec/24 hrs	N/A	Surface Insensitive Gen Instant Adhesive
*495	Clear		0.004	2500 psi	-65 to +180	20 sec/24 hrs	N/A	General Purpose Instant Adhesive
*496	Clear		0.005	2500 psi	-65 to +180	20 sec/24 hrs	N/A	Metal Bonding Adhesive
504	Brt Orange	515	0.030	750 psi	-65 to +300	90 min/24 hrs	None	Rigid Gasket Eliminator
509	Light Blue		0.020	750 psi	-65 to +320	6 hr/72 hrs	764	Flange Sealant
510	Red		0.020	1000 psi	-65 to +400	30 min/24 hrs	764	High Temperature, Gasket Eliminator
515	Purple		0.010	750 psi	-65 to +300	1 hr/24 hrs	764	Gasket Eliminator 515

Rac 8-98902

* Products 404-496 (except for #445) are all instant adhesives (super glues) they differ mostly in viscosity

Printed in U.S.A.

Click on the image link below for the full version of the service manual

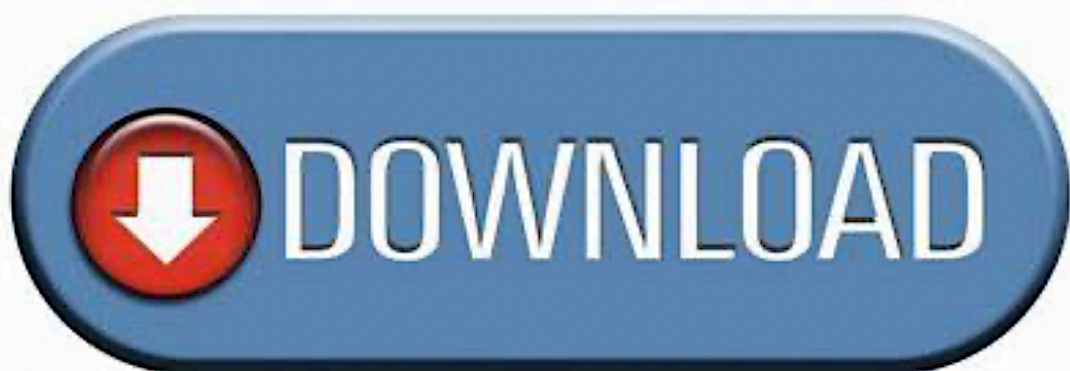

LOCTITE PRODUCT CHART

Product	Color	Similar Products	Gap (In Inches)	Strength (Steel/Steel)	Working Temperature Range-Fahrenheit	Fixture/Full Cure (Steel/Steel) Time	Primer	Description
518	Red	515	0.030	500psi	-65 to +300	1 hr/24 hrs	764	Gasket Eliminator 518 for Aluminum
542	Brown	569	N/A	132/92 in lbs	-65 to +300	2 hr/24 hrs	747	Hydraulic Sealant
545	Purple		N/A	25/20 in lbs	-65 to +300	4 hr/24 hrs	747	Low Strength Pneumatic/Hydraulic Sealant
549	Orange	504	0.020	2500 psi	-65 to +300	2 hr/24 hrs	747	Instant Seal Plastic Gasket
554	Red	277	0.015	240/240 in lbs	-65 to +300	2 to 4 hrs/24 hrs	764	Refrigerant Sealant
567	White	592	N/A	500 psi	-65 to +400	4 hrs/24 hrs	764	Pipe Sealant for Stainless Steel
568	Orange	277	0.015	2500 psi	-65 to +300	12 hrs/24 hrs	764	Plastic Gasket
569	Brown	545	0.010	40/25 in lbs	-65 to +300	1 hr/24 hrs	764	Hydraulic Sealant
570	Brown	592	N/A	25/40 in lbs	-65 to +300	6 hrs/72 hrs	764	Steam Sealant
571	Brown	592	0.015	40/20 in lbs	-65 to +300	2 to 4 hrs/24 hrs	764	Pipe Sealant
572	White	578.575	N/A	80/27 in lbs	-65 to +300	24 hrs/72 hrs	None	Gasketing
592	White		0.020	500 psi	-65 to +400	4 hrs/72 hrs	736	Pipe Sealant with Teflon
593	Black		0.250	400 psi	-95 to +400	30 min/24 hrs	N/A	RTV Silicone
601	Green	609	0.005	3000 psi	-65 to +300	10 min/24 hrs	764	Current PIN #609
609	Green		0.005	3000 psi	-65 to +300	10 min/24 hrs	764	General Purpose Retaining Compound
620	Green	640	0.015	3000 psi	-65 to +450	30 min/24 hrs	747	High Temperature Retaining Compound
635	Green	680	0.010	4000 psi	-65 to +300	1 hr/24 hrs	747	High Strength Retaining Compound
638	Green	680	0.015	4100 psi	-65 to +300	10 min/24 hrs	747	High Strength Retaining Compound
640	Green	620	0.007	3000 psi	-65 to +400	1 hr/24 hrs	747	High Temperature Retaining Compound
660	Silver		0.020	3000 psi	-65 to +300	20 min/24 hrs	764	Quick Metal
675	Green	609	0.005	3000 psi	-65 to +300	20 min/24 hrs	747	General Purpose Retaining Compound
680	Green	635	0.015	4000 psi	-65 to +300	10 min/24 hrs	747	High Strength Retaining Compound
706	Clear	755	N/A	N/A	N/A	N/A	N/A	Cleaning Solvent
707	Amber		N/A	N/A	N/A	N/A	N/A	Activator for Structural Adhesives
736	Amber		N/A	N/A	N/A	N/A	N/A	Primer NF
738	Amber		N/A	N/A	N/A	N/A	N/A	Depend Activator
747	Yellow	N/A	N/A	N/A	N/A	N/A	N/A	Primer T
751	Clear		N/A	N/A	N/A	N/A	N/A	Activator for Structural Adhesives
755	Clear		N/A	N/A	N/A	N/A	N/A	Cleaning Solvent
764	Green		N/A	N/A	N/A	N/A	N/A	Primer N
767	Silver		N/A	N/A	-65 to +1600	N/A	N/A	Anti-Seize Lubricant

1001

SAFETY RULES SERVICE MANUAL INTRODUCTION AND TORQUE SPECIFICATIONS

TABLE OF CONTENTS

Safety Rules	1001-2	Serial Numbers and Product Identification Numbers (PIN)	1001-5
Service Manual Introduction	1001-4	Torque Specifications	1001-6

SAFETY RULES

This Symbol Shows Important Information About Safety In This Manual. When You See This Symbol, Carefully Read The Information That Follows and Understand The Possible Causes of Injury Or Death. 1-1-A

IMPORTANT: To prevent personal injury on the job, follow the Warning, Caution, and Danger notes in this section and other sections throughout this manual. Follow the instructions carefully.

The procedures shown in this manual are good, effective service methods. However, every possible procedure and hazard may not be covered. Therefore, if you use a tool or procedure not shown, you must make sure that the method you select is a safe method.

Put the warning tag shown below on the key for the key switch when you service or repair this machine. One warning tag is on every new machine. You can buy additional warning tags, part number 331-4614, from Service Parts Supply.

DO NOT OPERATE

Reason _____

Signed by _____

780449

WARNING: Read operator's manual to familiarize yourself with control lever functions. 46-27

WARNING: Operate tractor and equipment controls from the seat position only. Any other method could result in serious injury. 48-55

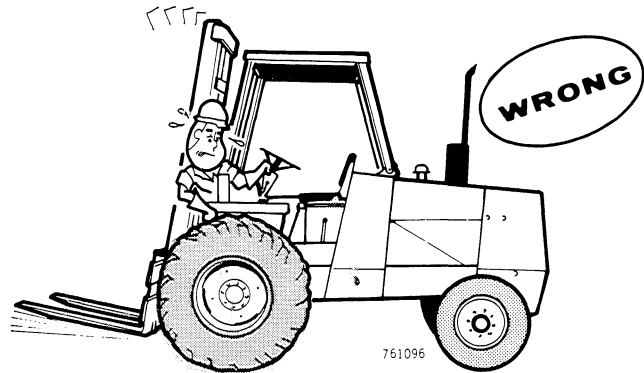

WARNING: This is a one man machine, no riders allowed. 35-8

DANGER: Engine exhaust fumes can cause death. If it is necessary to start the engine in a closed place, remove the exhaust fumes from the area with an exhaust pipe extension. If you do not have an exhaust pipe extension, open the doors and get outside air into the area. 48-56

WARNING: When working in the area of the fan belt with the engine running, avoid loose clothing if possible, and use extreme caution. 35-4



WARNING: If you wear clothing that is too loose or do not use the correct safety equipment for your job, you can be injured. Always wear clothing that will not catch on objects. Extra safety equipment that can be required includes hard hat, safety shoes, ear protection, eye or face protection, heavy gloves and reflector clothing.

45-3-A



CORRECT



CAUTION: Use suitable floor (service) jacks or chain hoists to raise wheels or track off the floor. Always block machine in place with suitable safety stands. 40-7-A



CAUTION: Some components of this machine are very heavy. Use suitable lifting equipment or additional help as instructed in this service manual. 40-10



WARNING: Locate the machine on level ground and block the wheels securely before working under the machine. Failure to follow the above procedure can result in personal injury. 46-77



CAUTION: When servicing or repairing the machine, keep the shop floor and operator's compartment and steps free of oil, water, grease, tools, etc. Use an oil absorbing material and/or shop cloths as required. Use safe practices at all times. 40-8



CAUTION: Pin sized and smaller streams of hydraulic oil under pressure can penetrate the skin and result in serious infection. If hydraulic oil under pressure does penetrate the skin, seek medical treatment immediately. Maintain all hoses and tubes in good condition. Make sure all connections are tight. Make a replacement of any tube or hose that is damaged or thought to be damaged. DO NOT use your hand to check for leaks; use a piece of cardboard or wood. 40-6-A



CAUTION: When removing hardened pins such as a pivot pin, or a hardened shaft, use a soft head (brass or bronze) hammer or use a driver made from brass or bronze and a steel head hammer. 46-17



CAUTION: When using a hammer to remove and install pivot pins or separate parts, using compressed air or using a grinder, wear eye protection that completely encloses the eyes (approved goggles or other approved eye protectors). 46-13



WARNING: When doing checks and tests on the equipment hydraulics, follow the procedures as they are written. DO NOT change the procedure. 47-44



WARNING: When putting the hydraulic cylinders on this machine through the necessary cycles to check operation or to remove air from a circuit, make sure all people are out of the way. 47-45



WARNING: Use insulated gloves or mittens when working with hot parts. 47-41A

SERVICE MANUAL INTRODUCTION

This service manual has been prepared with the latest service information available. Troubleshooting, removal, disassembly, inspection and installation procedures, and complete specifications and tightening references can be found in most sections. Some sections have drawings but no written procedure because the job is so easily done. This service manual is one of the most important tools available to the service technician.

Right, Left, Front, and Rear

The terms right-hand and left-hand and front and rear as used in this manual indicate the right and left sides, and front and rear of the machine as seen from the operator's seat for correct operation of the machine or attachment.

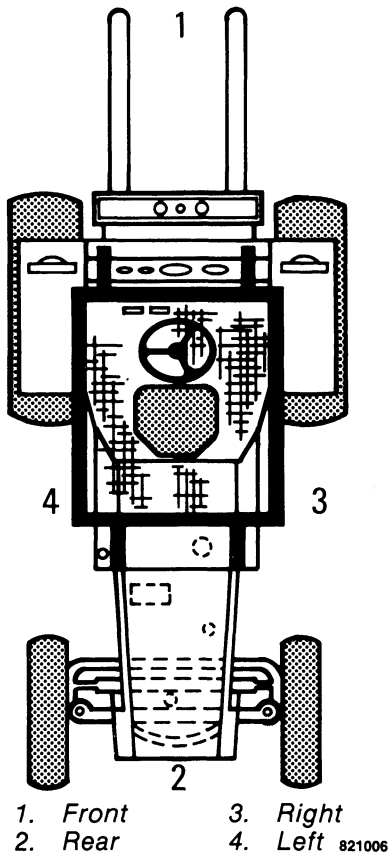

Text

If the service manual is for more than one machine or different models of components (planetary axles, gear boxes, control valves, etc.) the procedures have the steps necessary to service each model.

Table of Contents

A Table of Contents is in the front of this manual. The Table of Contents shows the main divisions and the sections that are in each division. The individual sections, where necessary, have a Table of Contents on the second page of that section.

Page Numbers

All page numbers are made of two numbers separated by a dash, such as 4002-9. The number before the dash is the section number. The number following the dash is the page number in that section. Page numbers will be found at the upper right or left of each page.

Illustration and Photos

Illustrations are put as near as possible to the test and are to be used as part of the test. Photos normally are put below the step to which they apply.

Clear and Simple English

This manual is written in C.A.S.E. (Clear and Simple English). C.A.S.E. is easier to read and understand than "regular" English because C.A.S.E. uses a small number of common words and has special rules for writing.

Special Tools

Special tools are needed to remove and install, disassemble and assemble, check and adjust some components of this machine. Some special tools can be made locally and the necessary information to make the tool is in this service manual. Other special tools are available from Service Tools in the U.S. and from Jobborn Manufacturing in Canada. Use these tools according to the instructions in this service manual for your personal safety and to do the job correctly.

Order special tools from either of the following companies:

Service Tools
P.O. Box 314
Owatonna, Minnesota 55060

Jobborn Manufacturing Co.
97 Frid Street
Hamilton, Ontario L8P 4M3
Canada

PRODUCT IDENTIFICATION NUMBER (PIN) AND SERIAL NUMBERS

NOTE: A serial number plate is also on some components such as the starter, alternator, pump etc.

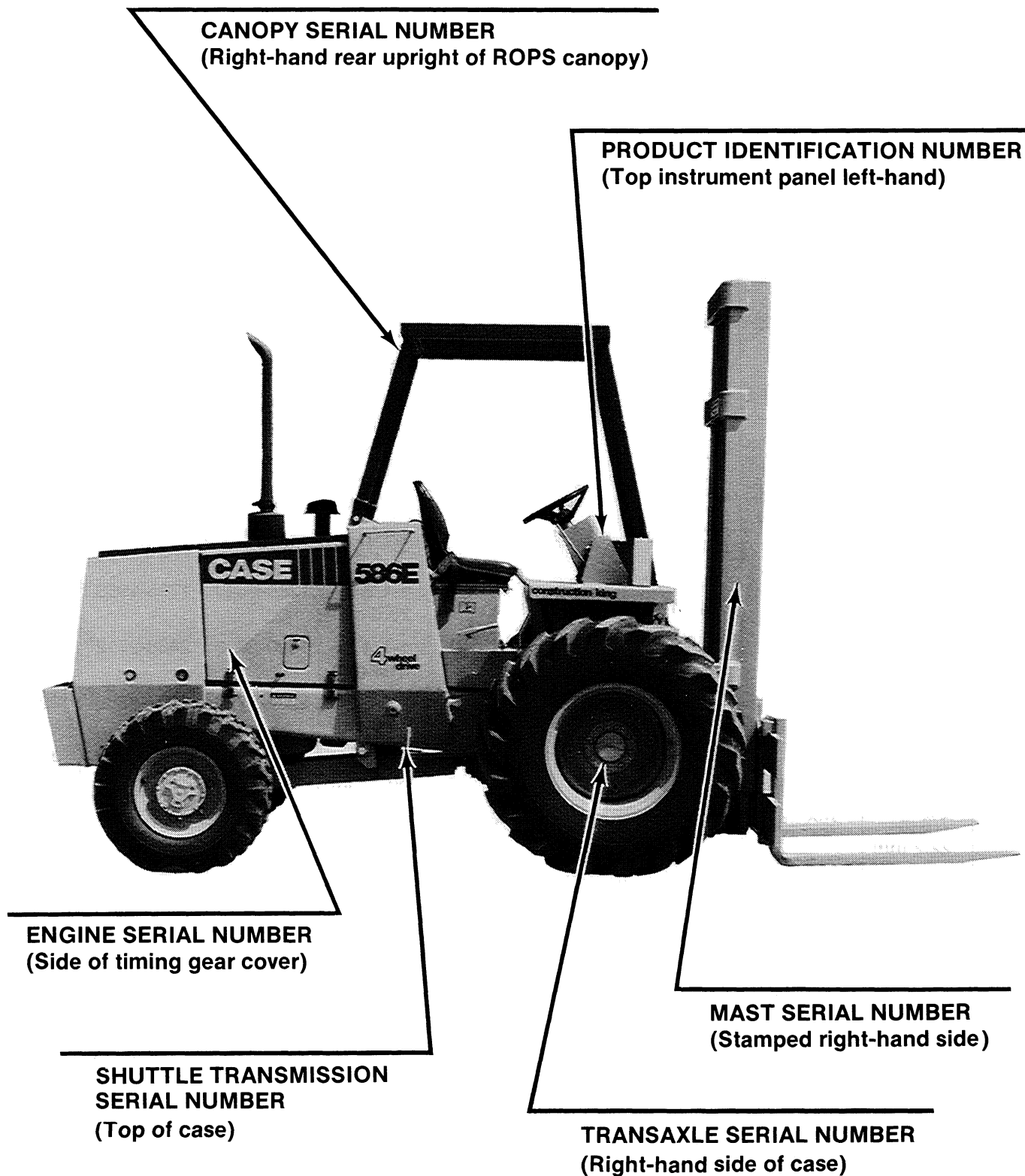

TORQUE SPECIFICATIONS - U.S. HARDWARE

Use the torques in this chart when special torques are not given. These torques apply to fasteners with both UNC and UNF threads as received from suppliers, dry, or when lubricated with engine oil. Not applicable if special graphites, moly-disulfide greases, or other extreme pressure lubricants are used.

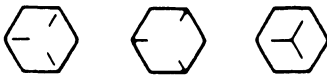
Grade 5 Bolts, Nuts, and Studs			
			
Size	Pound-Feet	Newton metres	Kilogram metres
1/4 in 6.4 mm	9-11	12-15	1.2-1.5
5/16 in 7.9 mm	17-21	23-28	2.4-2.9
3/8 in 9.5 mm	35-42	48-57	4.8-5.8
7/16 in 11.1 mm	54-64	73-87	7.5-8.8
1/2 in 12.7 mm	80-96	109-130	11.1-13.3
9/16 in 14.3 mm	110-132	149-179	15.2-18.2
5/8 in 15.9 mm	150-180	203-244	20.8-24.9
3/4 in 19.0 mm	270-324	366-439	37.3-44.8
7/8 in 22.2 mm	400-480	542-651	55.3-66.4
1.0 in 25.4 mm	580-696	787-944	80.2-96.2
1-1/8 in 28.6 mm	800-880	1085-1193	111-122
1-1/4 in 31.8 mm	1120-1240	1519-1681	155-171
1-3/8 in 34.9 mm	1460-1680	1980-2278	202-232
1-1/2 in 38.1 mm	1940-2200	2631-2983	268-304

Grade 8 Bolts, Nuts, and Studs			
			
Size	Pound-Feet	Newton metres	Kilogram metres
1/4 in 6.4 mm	12-15	16-20	1.7-2.1
5/16 in 7.9 mm	24-29	33-39	3.3-4.0
3/8 in 9.5 mm	45-54	61-73	6.2-7.5
7/16 in 11.1 mm	70-84	95-114	9.7-11.6
1/2 in 12.7 mm	110-132	149-179	15.2-18.2
9/16 in 14.3 mm	160-192	217-260	22.1-26.5
5/8 in 15.9 mm	220-264	298-358	30.4-36.5
3/4 in 19.0 mm	380-456	515-618	52.5-63.0
7/8 in 22.2 mm	600-720	814-976	83.0-99.5
1.0 in 25.4 mm	900-1080	1220-1465	124-149
1-1/8 in 28.6 mm	1280-1440	1736-1953	177-199
1-1/4 in 31.8 mm	1820-2000	2468-2712	252-277
1-3/8 in 34.9 mm	2380-2720	3227-3688	329-376
1-1/2 in 38.1 mm	3160-3560	4285-4827	437-492

TORQUE SPECIFICATIONS - METRIC HARDWARE

Use the following torques when special torques are not given.

These values apply to fasteners with coarse threads as received from supplier, plated or unplated, or when lubricated with engine oil. These values do not apply if graphite or moly-disulfide grease or oil is used.

Grade 8.8 Bolts, Nuts, and Studs			
			
Size	Pound-Feet	Newton metres	Kilogram metres
M4 0.15 in	2-3	3-4	0.3-0.4
M5 0.19 in	5-6	6.5-8	0.7-0.8
M6 0.23 in	8-9	10.5-12	1.1-1.2
M8 0.31 in	19-23	26-31	2.6-3.2
M10 0.39 in	38-45	52-61	5.3-6.2
M12 0.46 in	66-79	90-107	9.1-10.9
M14 0.55 in	106-127	144-172	14.7-17.6
M16 0.62 in	160-200	217-271	22.1-27.7
M20 0.78 in	320-380	434-515	44.2-52.5
M24 0.94 in	500-600	675-815	69.1-83.0
M30 1.17 in	920-1100	1250-1500	127-152
M36 1.40 in	1600-1950	2175-2600	221-270

Grade 10.9 Bolts, Nuts, and Studs			
			
Size	Pound-Feet	Newton metres	Kilogram metres
M4 0.15 in	3-4	4-5	0.4-0.5
M5 0.19 in	7-8	9.5-11	1.0-1.1
M6 0.23 in	11-13	15-17.5	1.5-1.8
M8 0.31 in	27-32	37-43	3.7-4.4
M10 0.39 in	54-64	73-87	7.5-8.8
M12 0.46 in	93-112	125-150	12.9-15.5
M14 0.55 in	149-179	200-245	20.6-24.7
M16 0.62 in	230-280	310-380	31.8-38.7
M20 0.78 in	450-540	610-730	62.2-74.7
M24 0.94 in	780-940	1050-1275	108-130
M30 1.17 in	1470-1770	2000-2400	203-245
M36 1.40 in	2580-3090	3500-4200	357-427

Grade 12.9 Bolts, Nuts, and Studs



Usually the torque values specified for grade 10.9 fasteners can be used satisfactorily on grade 12.9 fasteners.

TORQUE SPECIFICATIONS - STEEL HYDRAULIC FITTINGS

Tube OD Hose ID	Thread Size	Pound- Feet	Newton metres	Kilogram metres
37 Degree Flare Fittings				
1/4 in 6.4 mm	7/16-20	6-12	8-16	0.8-1.7
5/16 in 7.9 mm	1/2-20	8-16	11-21	1.1-2.2
3/8 in 9.5 mm	9/16-18	10-25	14-33	1.4-3.5
1/2 in 12.7 mm	3/4-16	15-42	20-56	2.1-5.8
5/8 in 15.9 mm	7/8-14	25-58	34-78	3.5-8.0
3/4 in 19.0 mm	1-1/16-12	40-80	54-108	5.5-11.1
7/8 in 22.2 mm	1-3/16-12	60-100	81-135	8.3-13.9
1.0 in 25.4 mm	1-5/16-12	75-117	102-158	10.4-16.2
1-1/4 in 31.8 mm	1-5/8-12	125-165	169-223	17.3-22.8
1-1/2 in 38.1 mm	1-7/8-12	210-250	285-338	29.0-34.6

Tube OD Hose ID	Thread Size	Pound- Feet	Newton metres	Kilogram metres
Straight Threads with O-ring				
1/4 in 6.4 mm	7/16-20	12-19	16-25	1.7-2.6
5/16 in 7.9 mm	1/2-20	16-25	22-33	2.2-3.5
3/8 in 9.5 mm	9/16-18	25-40	34-54	3.5-5.5
1/2 in 12.7 mm	3/4-16	42-67	57-90	5.8-9.3
5/8 in 15.9 mm	7/8-14	58-92	79-124	8.0-12.7
3/4 in 19.0 mm	1-1/16-12	80-128	108-174	11.1-17.8
7/8 in 22.2 mm	1-3/16-12	100-160	136-216	13.8-22.1
1.0 in 25.4 mm	1-5/16-12	117-187	159-253	16.2-25.9
1-1/4 in 31.8 mm	1-5/8-12	165-264	224-357	22.8-36.5
1-1/2 in 38.1 mm	1-7/8-12	250-400	339-542	34.6-55.3

Split Flange Mounting Bolts			
Size	Pound- Feet	Newton metres	Kilogram metres
5/16-18	15-20	20-27	2.1-2.8
3/8-16	20-25	26-33	2.8-3.5
7/16-14	35-45	47-61	4.7-6.2
1/2-13	55-65	74-88	7.6-9.0
5/8-11	140-150	190-203	19.4-20.7

Section 1002

FLUIDS AND LUBRICANTS

TABLE OF CONTENTS

Capacities and Lubricants	2
Engine Oil Recommendations	3
Diesel Fuel.....	4

CAPACITIES AND LUBRICANTS

FUEL TANK

Capacity.....	26.5 U.S. gallons (100 litres)
Type of fuel.....	See Diesel Fuel Specifications 1002-4

ENGINE OIL

Capacity with filter change.....	11 U.S. quarts (10.4 litres)
Type of oil.....	See Engine Oil Recommendations 1002-3

HYDRAULIC FLUID RESERVOIR

Refill capacity with filter change.....	13.6 U.S. gallons (51.5 litres)
without filter change	13.3 U.S. gallons (50 litres)
Total system capacity.....	15.25 U.S. gallons (58 litres)
Type of fluid.....	Case TCH Fluid

POWER SHUTTLE TRANSMISSION

Capacity.....	8 U.S. quarts (7.6 litres)
Type of fluid.....	Case TCH Fluid

FOUR SPEED TRANSAXLE

Capacity.....	20 U.S. quarts (19 litres)
Type of lubricant.....	Case IH 135-H EP Gear Lube

ENGINE COOLING SYSTEM

Capacity.....	18.2 quarts (17.2 litres)
Type of coolant.....	Ethylene glycol type antifreeze and water that is mixed 50% ethylene glycol and 50% water.

REAR DRIVE AXLE

Capacity of the center bowl	7 U.S. quarts (6.6 litres)
Capacity of each planetary end.....	1.5 U.S. quarts (1.4 litre)
Type of Lubricant.....	Case IH 135-H EP Gear Lube

TRANSFER CASE

Capacity.....	1 U.S. pint (0.5 litre)
Type of lubricant.....	Case IH 135-H EP Gear Lube

BATTERY

Capacity.....	As required
Type of fluid.....	Use drinking or distilled water only

GREASE FITTINGS

Quantity.....	As required
Type of lubricant.....	Case Molydisulfide grease

WHEEL BEARINGS (Rear Wheels)

Capacity.....	As required
Type of lubricant.....	Number 2 wheel bearing grease

Engine Oil Recommendations

Case IH No. 1 Engine Oil is recommended for use in your Case IH Engine. Case IH Engine Oil will lubricate your engine correctly under all operating conditions. If Case IH No. 1 Multi-Viscosity Engine Oil is not available, Case IH No. 1 Single Grade Engine Oil can be used.

If Case IH No. 1 Multi-Viscosity or Single Grade Engine Oil is not available, use only oil meeting API engine oil service category CE.



654L9

See the chart below for recommended viscosity at ambient air temperature ranges.

NOTE: Do not put Performance Additives or other oil additive products in the engine crankcase. The oil intervals given in this manual are according to tests with Case IH lubricants.

Engine Oil Viscosity

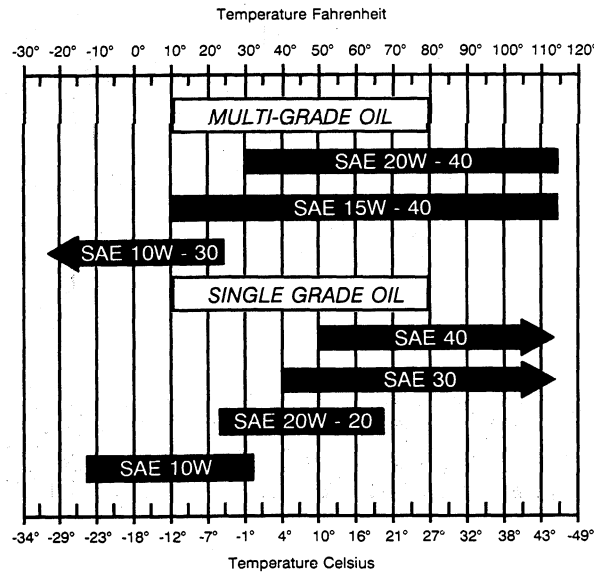

737L9

DIESEL FUEL

Use No. 2 diesel fuel in the engine of this machine. The use of other fuels can cause the loss of engine power and high fuel consumption.

In very cold temperatures, a mixture of No. 1 and No. 2 diesel fuels is temporarily permitted. See the following Note.

NOTE: See your fuel dealer for winter fuel requirements in your area. If the temperature of the fuel lowers below the cloud point (wax appearance point), wax crystals in the fuel will cause the engine to lose power or not start.

The diesel fuel used in this machine must meet the specifications in the chart below or Specification D975-81 of the American Society for Testing and Materials.

Fuel Storage

If you keep fuel in storage for a period of time, you can get foreign material or water in the fuel storage tank. Many engine problems are caused by water in the fuel.

Keep the fuel storage tank outside and keep the fuel as cool as possible. Remove water from the storage container at regular periods of time.

Fill the fuel tank at the end of the daily operating period to prevent condensation in the fuel tank.

Specifications for Acceptable No. 2 Diesel Fuel

API gravity, minimum	34
Flash point, minimum	140°F (60°C)
Cloud point (wax appearance point), maximum	-5°F (-20°C) See Note above
Pour point, maximum	-15°F (-26°C) See Note above.
Distillation temperature, 90% point	540 to 640°F (282 to 338°C)
Viscosity, at 100°F (38°C)	
Centistokes	2.0 to 4.3
Saybolt Seconds Universal	32 to 40
Cetane number, minimum	43 (45 to 55 for winter or high altitudes)
Water and sediment, by volume05 of 1%
Sulfur, by weight, maximum50 of 1%
Copper strip corrosion, maximum	No. 2
Ash, by weight, maximum01 of 1%



Engine fuel is flammable and can cause a fire or an explosion. Do not fill the fuel tank or service the fuel system near an open flame, welding, burning cigars, cigarettes, etc.

SA022

Section 1010

GENERAL ENGINE SPECIFICATIONS

Written In *Clear
And
Simple
English*

IMPORTANT: *This engine was made using the measurement system. All measurements and checks must be made with metric tools to make sure of an accurate reading when inspecting parts.*

ENGINE SPECIFICATIONS

General

Type	4 Cylinder, 4 Stroke Cycle, Valve-In-Head
Firing Order	1,3,4,2
Bore	102 mm
Stroke	120 mm
Piston Displacement	3.92 Litres
Compression Ratio	17.0 to 1
No Load Governed Speed	2345 to 2440 RPM
Rated Engine Speed	2305 to 2385 RPM
Engine Idle Speed	850 to 900 RPM
Valve Tappet Clearance (Exhaust)(Cold)	0.508 mm
(Intake)(Cold)	0.254 mm
Thermostat Operating Range	181°F to 203°F (83°C to 95°C)

Piston and Connecting Rods

Rings Per Piston	3
Number of Compression Rings	2
Number of Oil Rings (two piece)	1
Type of Pins	Full Float
Type Bearings	Steel Back Leaded Bronze

Main Bearings

Number of Bearings	5
Type of Bearings	Replaceable

Engine Lubricating System

Oil Pressure	42 to 54 PSI (290 to 372 kPa)(2.90 to 3.72 bar) with Engine Warm at Rated Engine Speed
Type of System	Pressure and Spray Lubrication
Oil Pump	Rotor Type
Oil Filter	Full Flow Turn on Type
Oil Capacity (with filter)	11 Quarts (10.4 litres)
(without filter)	10 Quarts (9.5 litres)

Fuel System

Fuel Injection Pump	CAV
Pump Timing	Top Center
Fuel Injectors	Bosch 17 mm Opening Pressure (New) 3190 to 3310 PSI (21 994 to 22 821 kPa)(220 to 228 Bar)
Governor	Variable Speed, a Part of the Injection Pump
First Stage Fuel Filter	Turn on Type
Second Stage Fuel Filter	Turn on Type
Lift Pump	5 to 7 PSI (34 to 48 kPa)(0.34 to 0.48 Bar)

2000

ENGINE AND RADIATOR REMOVAL AND INSTALLATION

TABLE OF CONTENTS

Engine Removal	2000-2	Radiator Removal	2000-29
Removing Power Shuttle and Torque Converter From Engine	2000-14	Illustration of Radiator Installation	2000-35
Installing Power Shuttle and Torque Converter To Engine	2000-16	Radiator Installation	2000-36
Engine Installation	2000-17		

ENGINE REMOVAL

1. Park the machine on a level surface and apply the parking brake.

2. Lower the forks to the floor.

3. Remove the side panels.



520011

4. Loosen the nuts and lock washers on the clamp that holds the muffler.

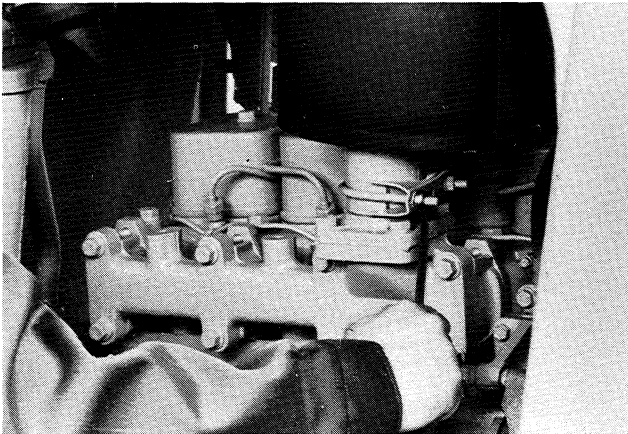

520013

5. Remove the muffler. Cover or close the opening in the exhaust flange.

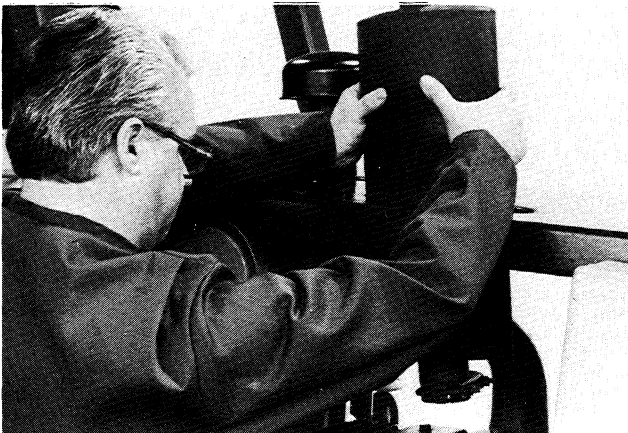

520015

6. Remove the cap from the air cleaner.



520017

7. Loosen and remove the cap screws, lock washers, and flat washers that fasten the hood brackets to the radiator shroud.

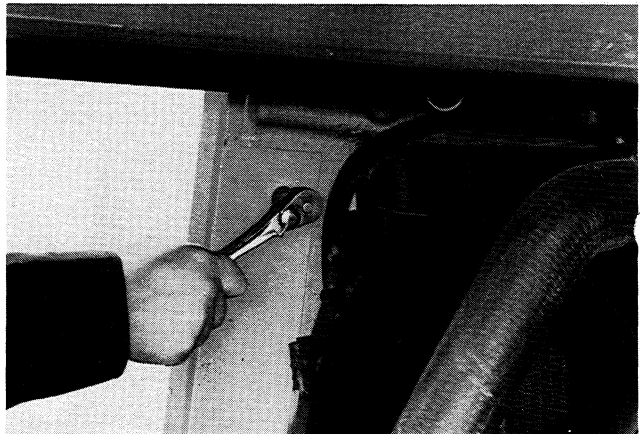

520019

8. Remove both hood brackets.



520022

9. Loosen and remove the cap screws and flat washers that fasten the rear of the hood to the grille.

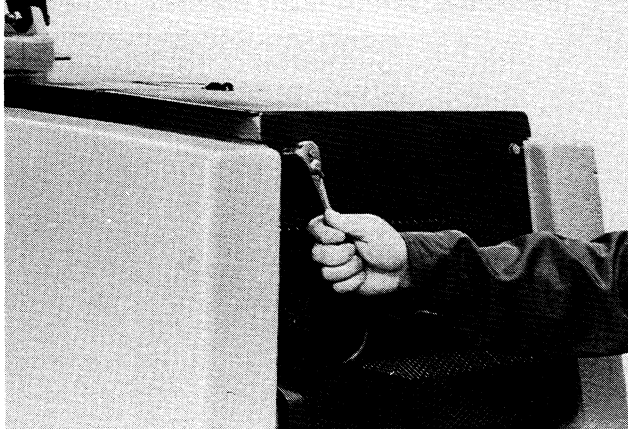

520024

10. Remove the hood.

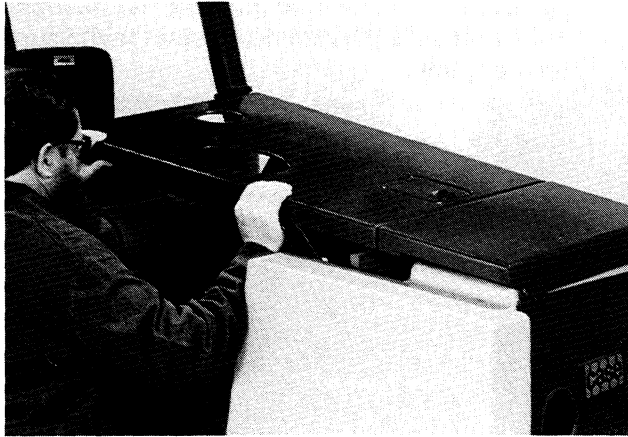

520026

11. Loosen and remove the cap screws and flat washers that hold the grille. Lower the grille enough to get access to the rear lamp wires.



520028

12. Disconnect the wires.

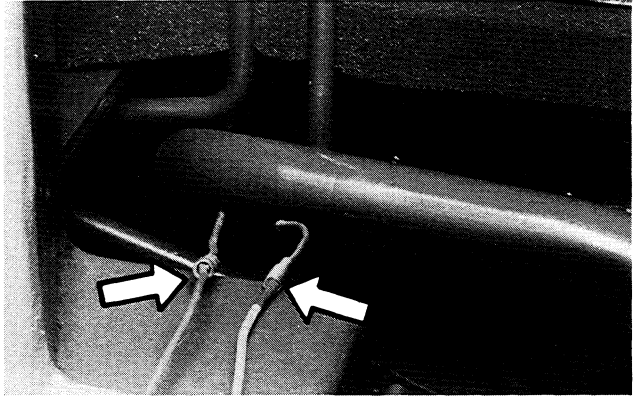

520030

13. If the machine has an outer counterweight and a center counterweight:

a. Install an acceptable lifting eye in the outer counterweight and connect a chain hoist to the lifting eye.

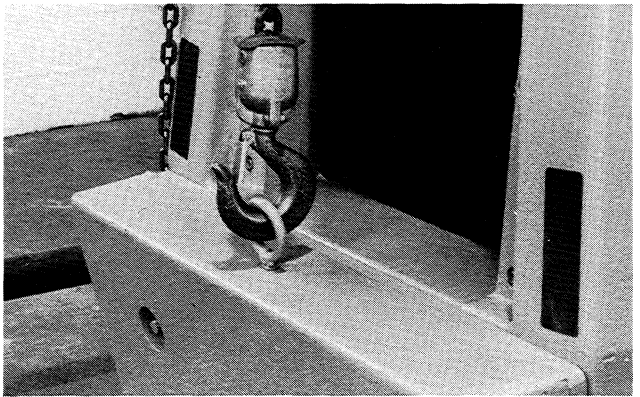

520035

NOTE: The outer counterweight has a weight of approximately 650 pounds (295 kg). The center counterweight has a weight of approximately 145 pounds (66 kg).

b. Loosen and remove the nuts and flat washers from the studs that hold the outer counterweight and the center counterweight.

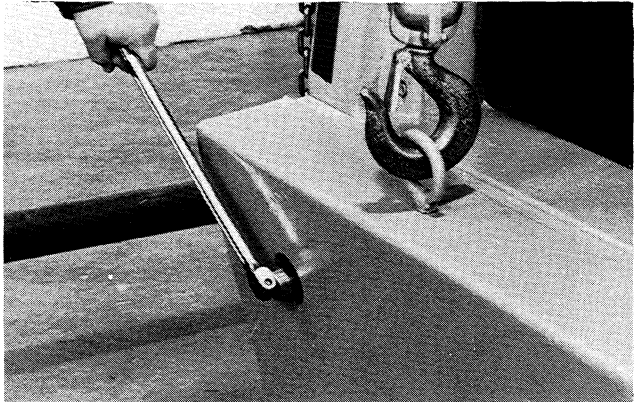

520037

c. Carefully separate the outer counterweight and the center counterweight from the radiator shroud. Connect a chain around both counterweights.

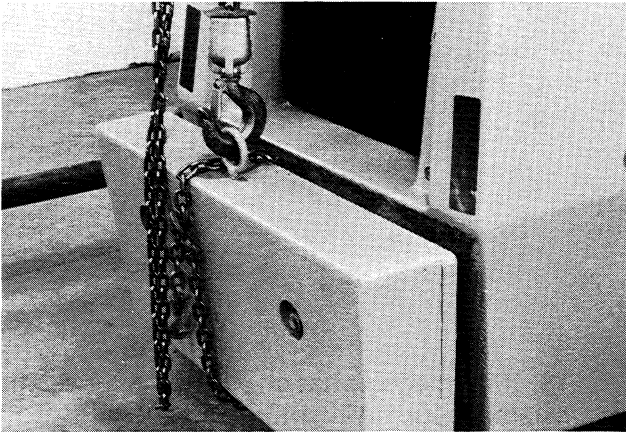

520039

d. Lower both counterweights and move the counterweights out of the way.

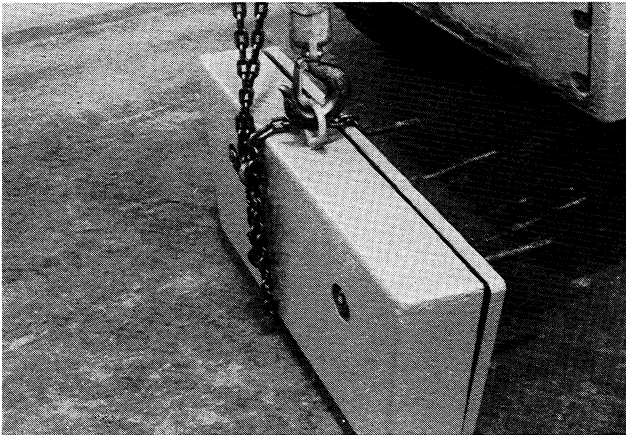

520041

14. Connect a chain hoist to the radiator shroud.

NOTE: The radiator shroud and the inner counterweight can be removed as an assembly. The inner counterweight has a weight of approximately 455 pounds (207 kg). The radiator shroud and the inner counterweight together have a weight of approximately 3,145 pounds (1426 kg).

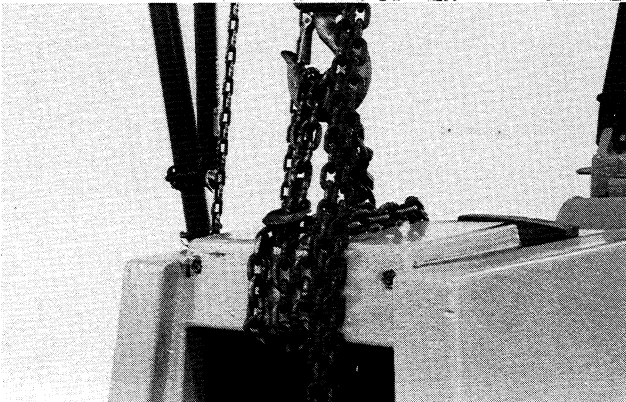

520043

15. Loosen and remove the self-locking nuts, bolts, and flat washers that fasten the mounting straps on the radiator shroud to the brackets on the radiator.

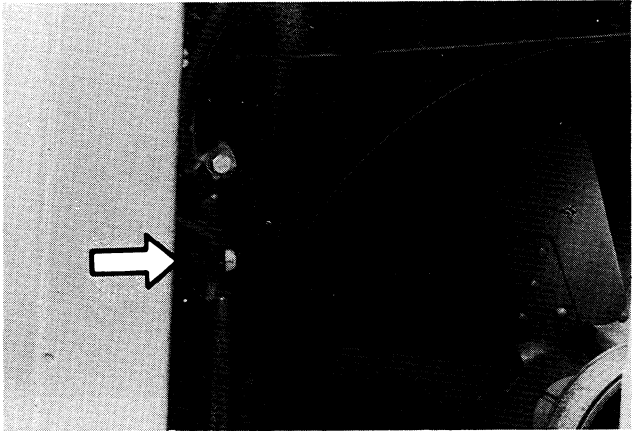

520001

16. Loosen and remove the nuts, flat washers, and bolts that hold the radiator shroud to the supports on the frame.

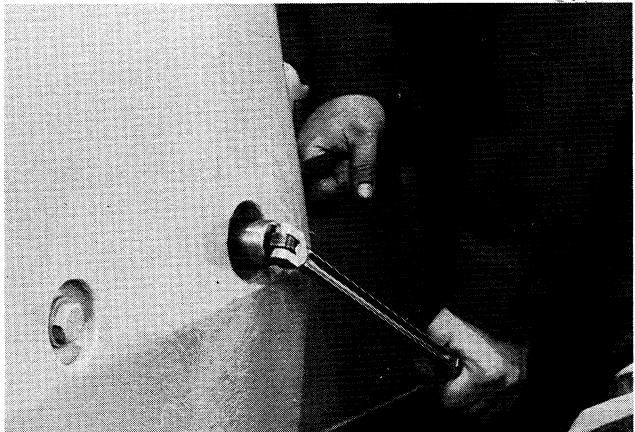

520110

17. Loosen and remove the nuts and flat washers from the bolts that hold the radiator shroud to the ends of the frame.

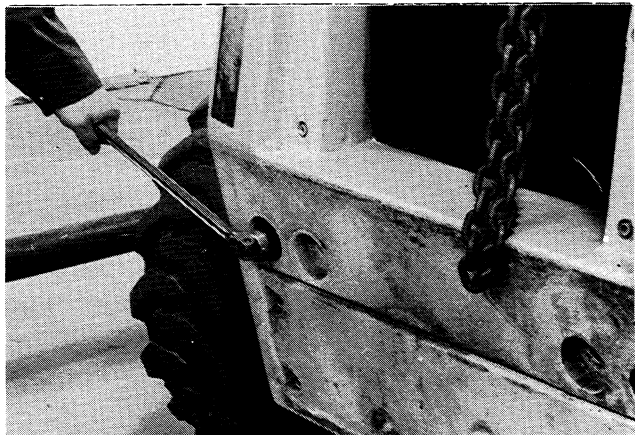

520108

18. Make a record of the number and thickness of the spacers between the radiator shroud and the ends of the frame. The spacers must be installed the same way during installation. Remove the bolts, flat washers, and spacers.

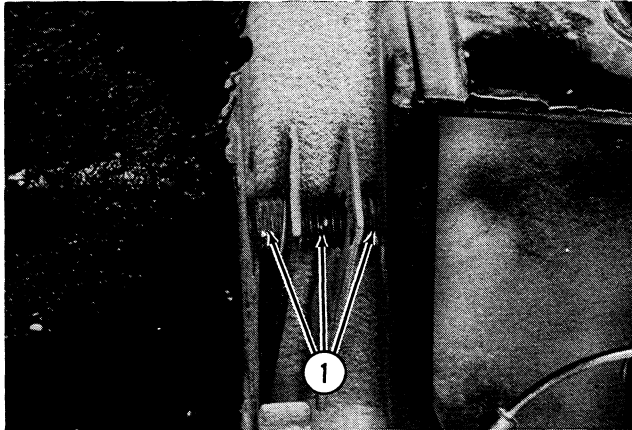

1. Spacers

220925

19. Move the radiator shroud to the rear and lower the radiator shroud to the floor.

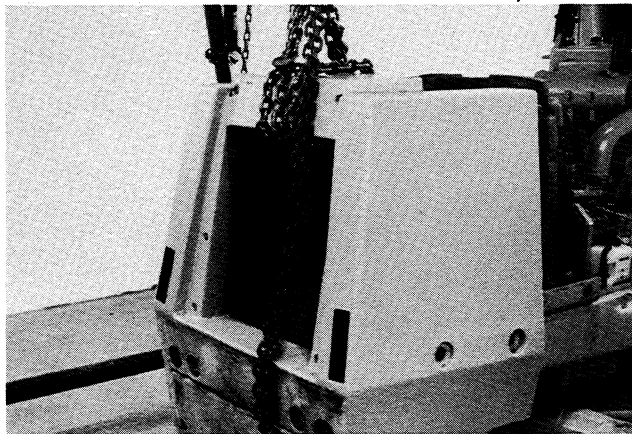

520112

20. Loosen and remove the cap from the radiator.

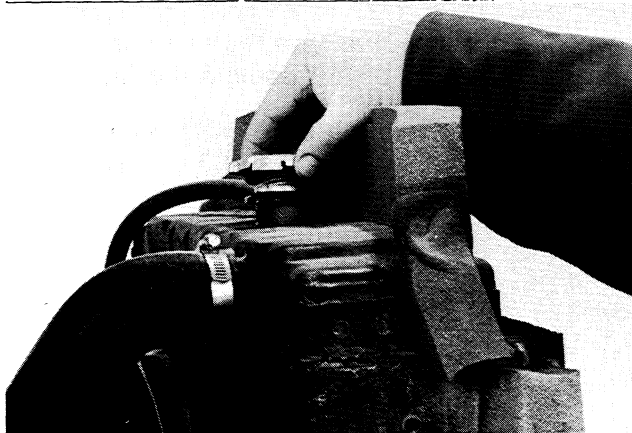

520116

21. Install a hose on the drain valve of the radiator.

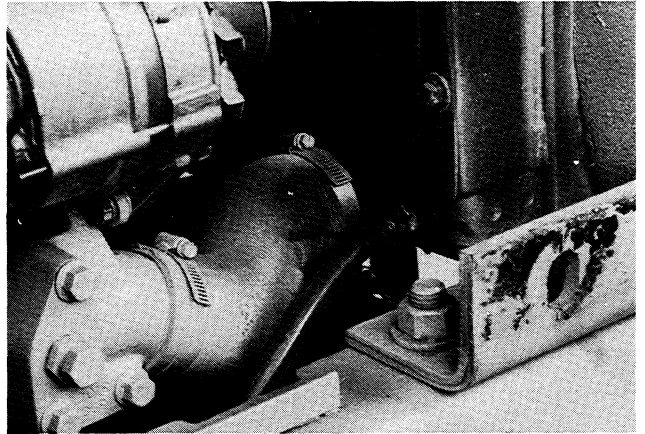

520114

22. Drain the cooling system, The cooling system holds 18.2 U.S. quarts (17.2 litres) of coolant.

23. Loosen the clamp on the bottom radiator hose at the radiator.

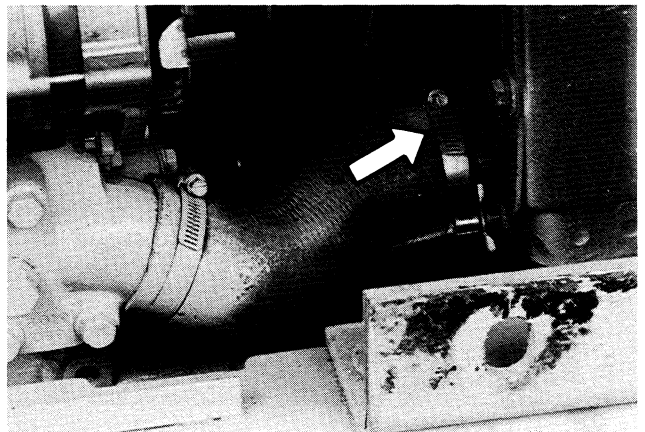

520118

24. Loosen the clamp on the top radiator hose and disconnect the hose.



520120

25. Loosen the clamps on the hoses for the oil cooler. Slide the hoses down the tubes and install plugs in the hoses and caps on the tubes.

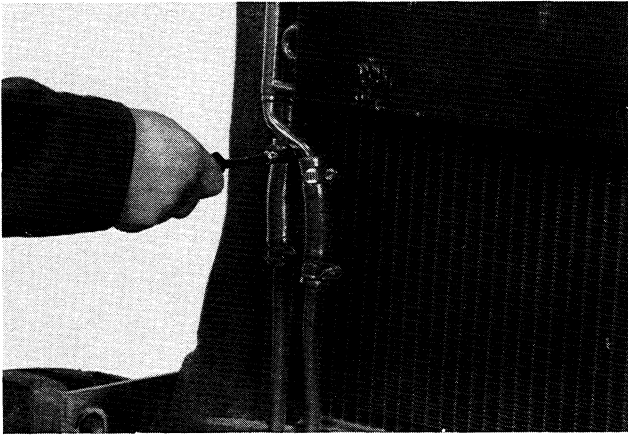

520140

26. Disconnect the hose from the fill neck of the radiator. Install a plug in the hose.



520126

27. Loosen and remove the cap screw, lock washer, and flat washer that fasten the upper clamp for the hose to the fan shroud and radiator.

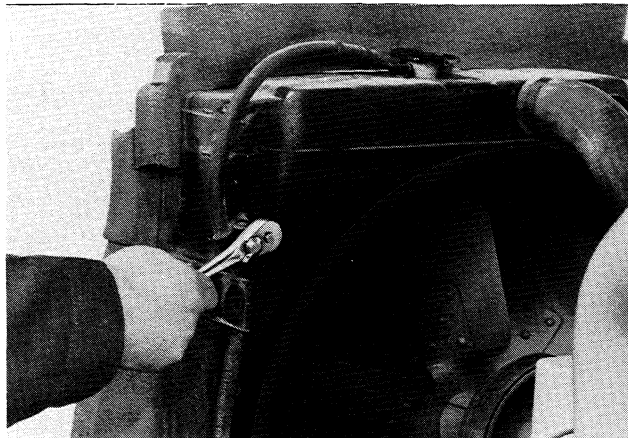

520128

28. Loosen and remove the cap screws, lock washers, and flat washers that fasten both sides of the fan shroud to the radiator.

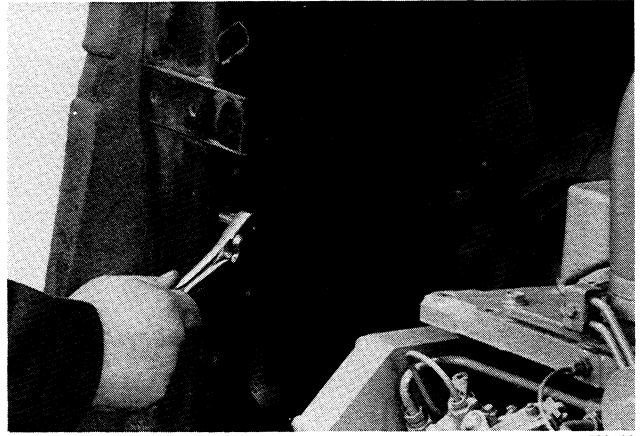

520130

29. Loosen and remove the remaining cap screw, lock washer, and flat washer that fasten the clamp for the hose to the bottom of the fan shroud and radiator. Move the hose out of the way.

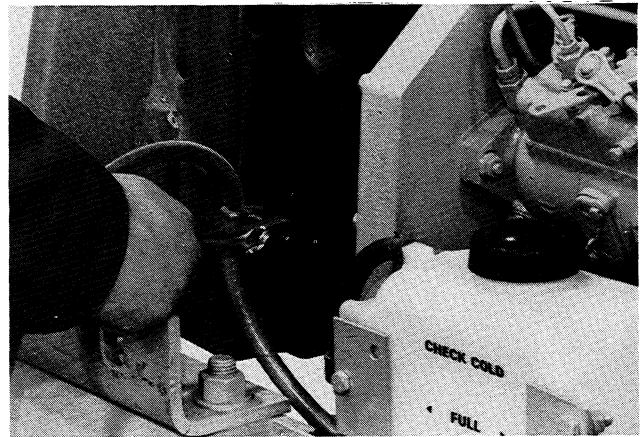

520132

30. Put the fan shroud over the fan. See photo for Step 32.

31. Loosen and remove the self-locking nuts, flat washers, and bolts that hold the radiator to the frame.

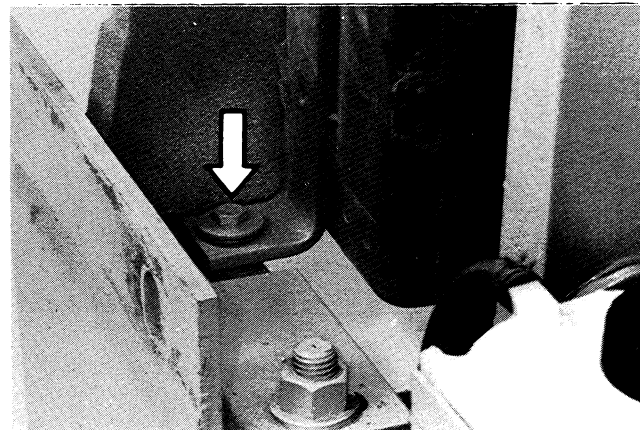

520134

32. Disconnect the bottom radiator hose and remove the radiator and oil cooler from the machine. Do not lose the spacers between the radiator mounts and the frame. Remove the fan shroud from the fan.

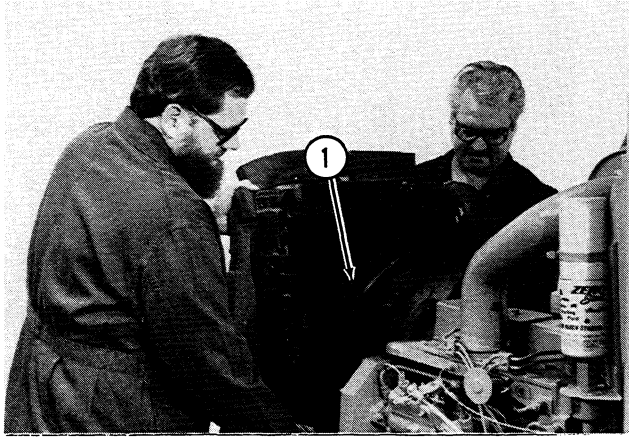

1. Fan Shroud

520136

33. Disconnect the ground cable from the battery.

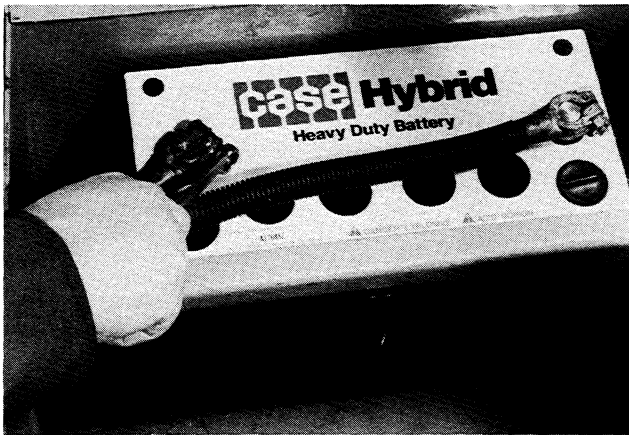

520212

34. Loosen and remove the nuts, lock washers, flat washers and bolts that hold the coolant reservoir. Remove the coolant reservoir and hose.

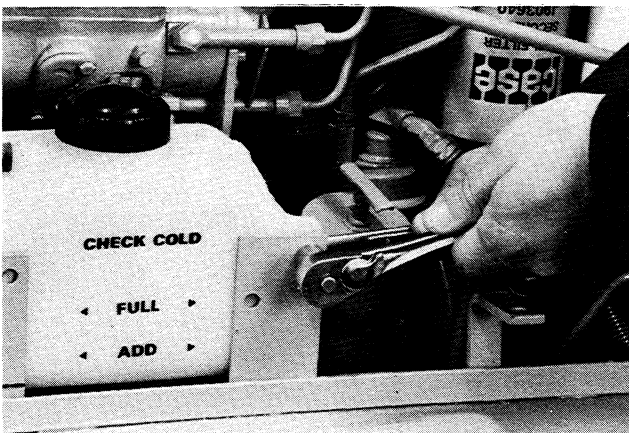

520214

35. Disconnect the throttle rod from the lever on the fuel injection pump.

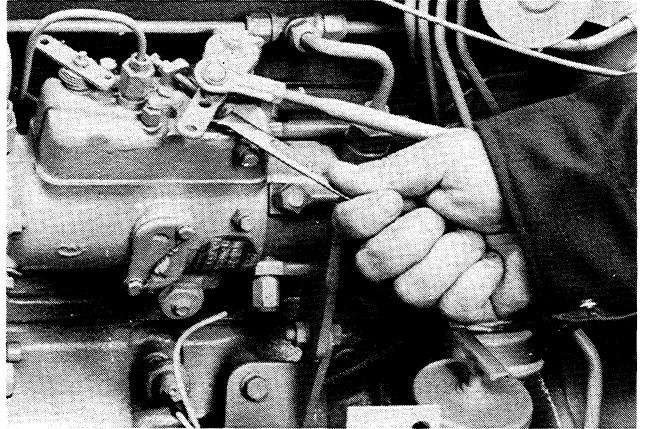

520216

36. Disconnect the other end of the throttle rod and remove the throttle rod.

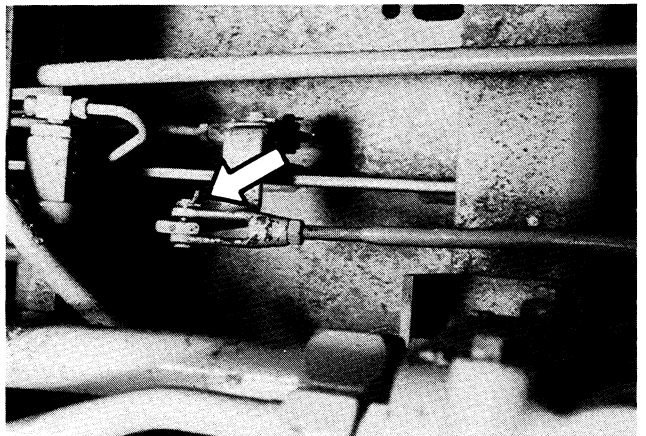

520220

37. Close the shutoff valve in the bottom of the fuel tank.

38. If equipped with ether injection:

a. Disconnect the tube from the intake manifold.

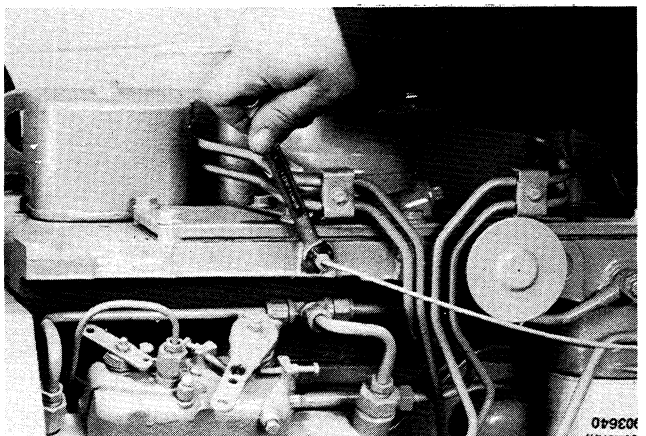

07960X
520228